

GK337D3 Series

ELECTRIC AUTOMATIC TRIMMER DEVICE

Installation Manual Parts List

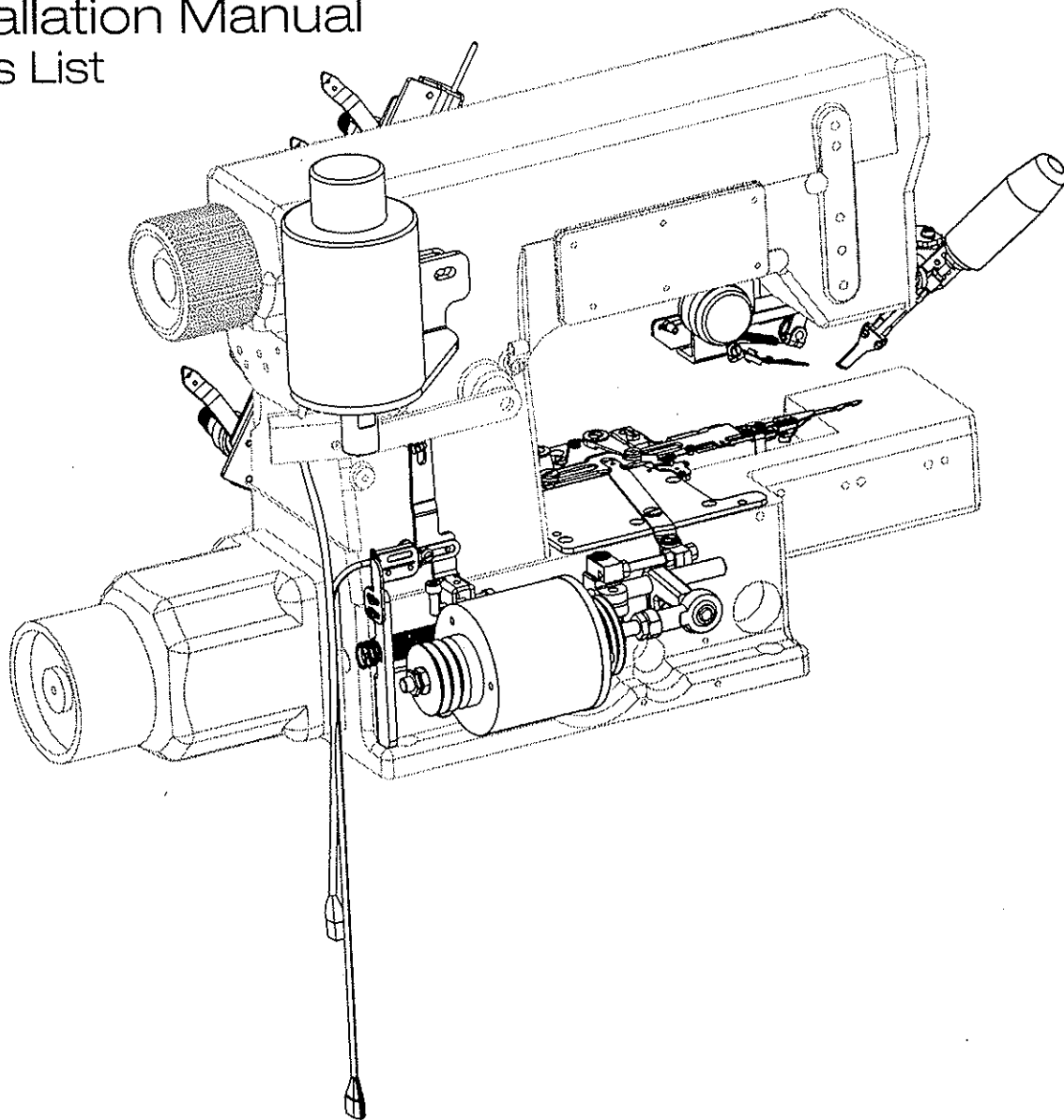

Caution

- Follow the installation manual can help you finish the installation in a short time;
- Before installation, assure the electric control box input voltage is AC220V and the output voltage is DC24V;
- After mounted, assure the trimmer electromagnet ground cable (yellow green cable) is connected to the ground.



Warning

Shut down the power breaker before installation and only the technician people can operate.

The components of the automatic trimmer device:

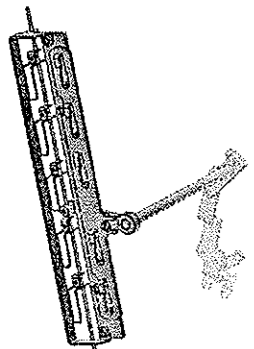

(TT)
Thread releaser

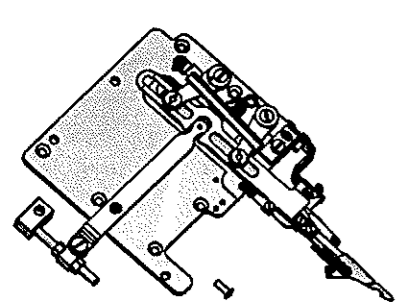

(UT)
Under-bed trimmer

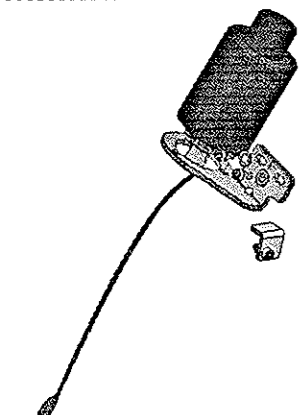
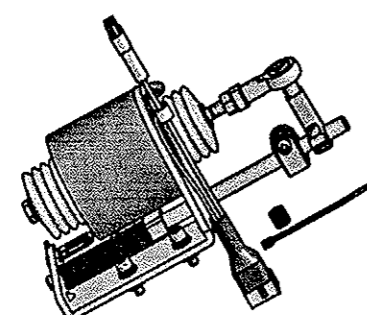

(LFE)
Presser foot lifter



(WP)
Wiper device

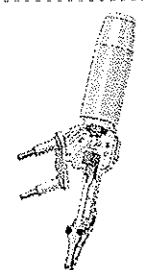

(ST)
Top trimmer



Caution

Please check the outside package box marks. The ticks represent the devices you buy.

GK337D3

UT INSTALLATION AND ADJUSTING

1、 Install the lower cutting device use screw 1,2 to fix the cutter assy.

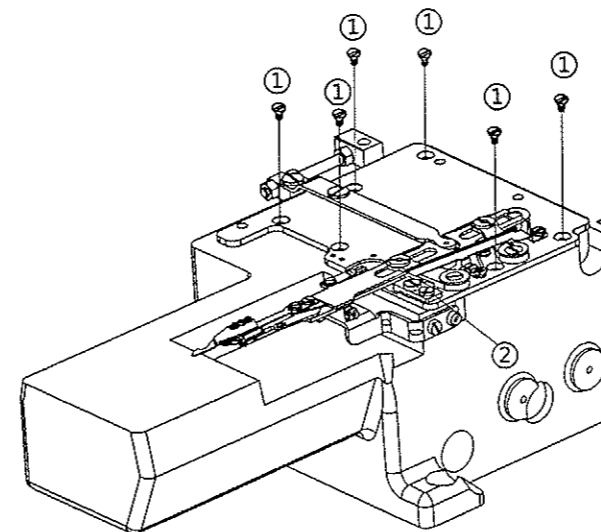

Figure 1

2、 Adjustment of lower cutting device:

Make P align to " ", needle in upper position and looper in front position.

【 A 】 Move movable knife to cutting limit position;

【 B 】 The distance between 2 on movable knife 1 and turn knob of looper 5 is 12mm, make 2 aligned with the inner edge of the looper upper side 1/3;

【 C 】 Release 3 and adjust 4, make movable knife tip horizontal swing, make adjustment;

【 D 】 After adjustment, tighten 3.

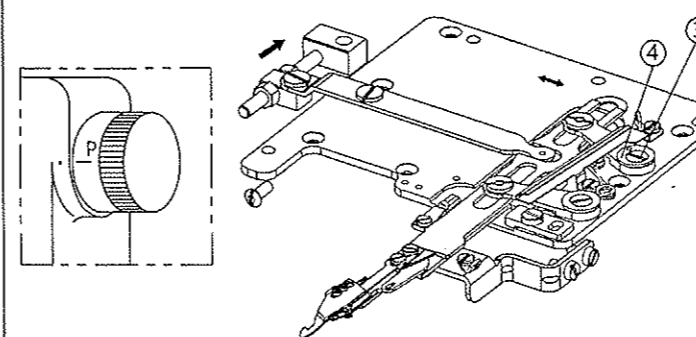

Figure 2

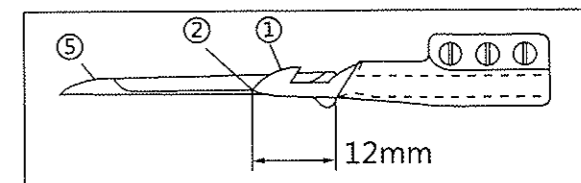

Figure 3

3、 Lower cutting knife height adjustment release 1 and adjust 2, make the distance between movable knife lower side and looper is 0-0.1mm, then tighten 1.

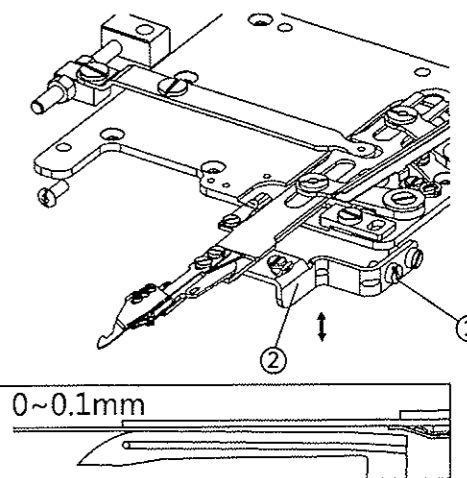

Figure 4

4、 Adjustment of movable knife and needle position:

【 A 】 Release 3 and move movable knife to the nearest position to the needle.

【 B 】 Adjust 4 and make the distance between A and needle center 22mm, and aligned to left side of thread hole of looper 2.

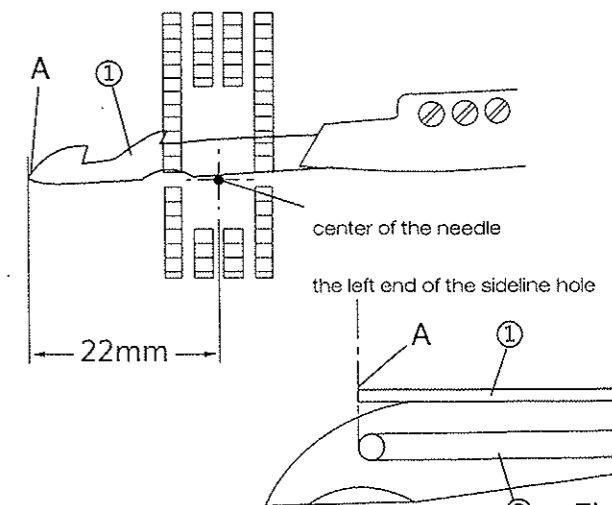
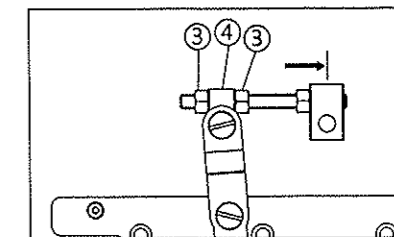

Figure 5

【 C 】 The installation position of spring 4 is 1.5mm far from the tip of fixed knife, release the screw 3 for adjustment.

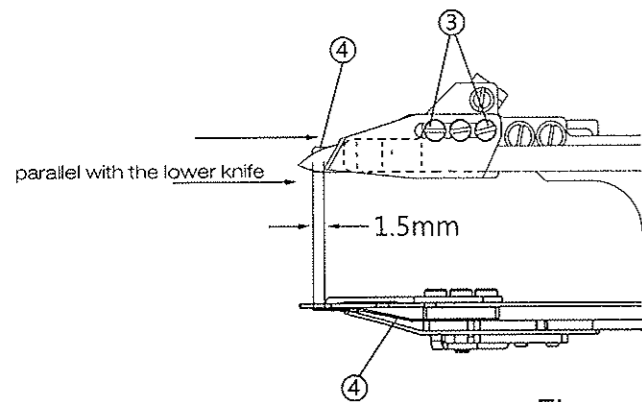

Figure 6

【 D 】 To put lower thread holding device 5 3mm away from the top of fixed knife, loosen the screw 6 to adjust the position of lower thread holding device to parallel the movable knife. The pressure of thread holding device could be adjust by the screw 7. The strength of thread holding device is around 0.1 Kilo gram, cannot be large or small.

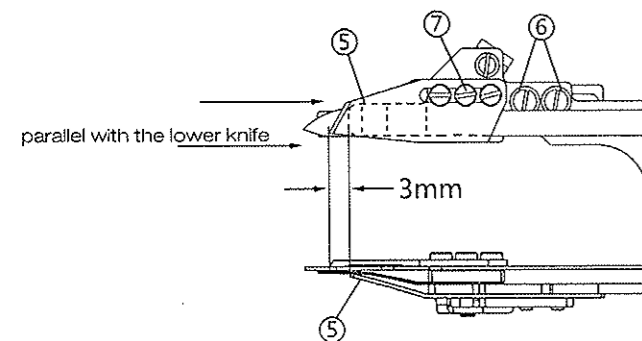

Figure 7

5、 The installation of the solenoid for lower thread cutter ass. and adjust and connection for the lower cutter:

【 A 】 To fix the solenoid 3 with screw 1 and washer 2 on the head.

【 B 】 To put the cutter position adjust device 4 and fasten the screw 5 of lower cutter system. The fig 8 is the finished installation of solenoid.

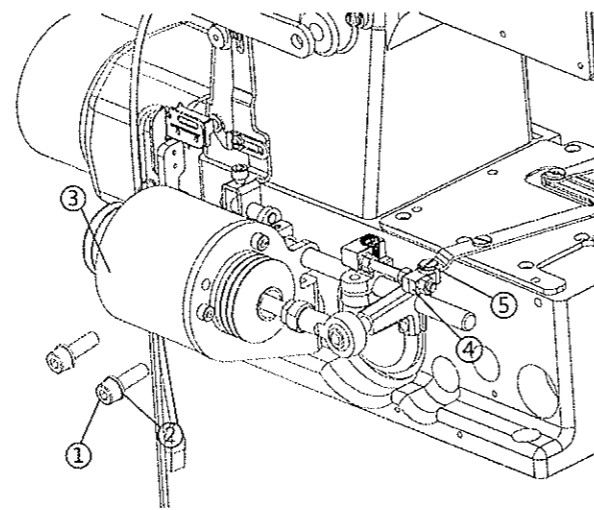

Figure 8

【 C 】 To check the the efficiency of the cutting system: Checking if the thread for looper and needle could be cut smoothly and tidily and check if the thread for looper could be clamp by the lower thread tension shrapnel 4. The pressure of thread tension shrapnel should be adjust when it is out of work and the pressure shrapnel 3 should be adjust when the thread cutter is out of work.

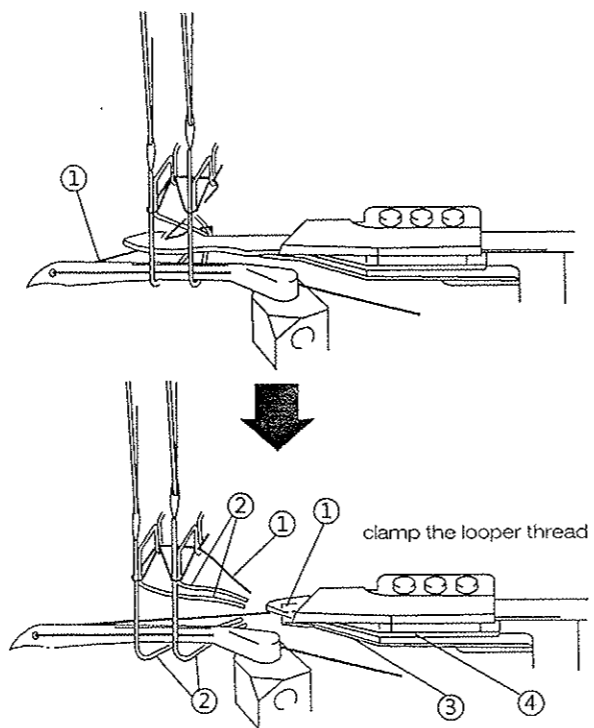

Figure 9

1、 Put the driving lever 1 into the circle, and connect it with crank rod 2, present no need lock crank screw 3, while add lubrication into driving lever circle.

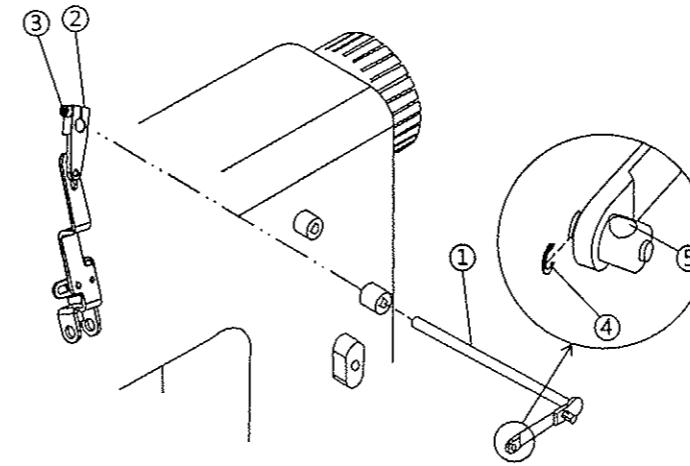

Figure 10

2、 Install bracket 6 on thread release plate 7, and lock screw 8.

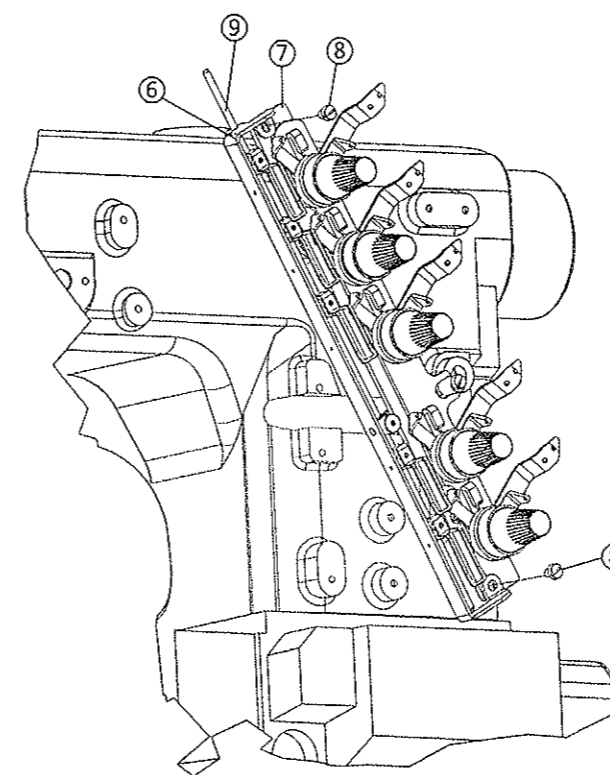

Figure 11

3、 Pass thread release bar 9 thru thread release plate and fix into the hole of shaft 5, lift thread release bar to 30mm, lock screw 11.

4、 Thread release device adjusting:

【 A 】 Release screw 11, then adjust thread release bar to make sure that the distance between thread tension plate and the pawl of seperation plate 10 is 0.5mm, then lock screw 3 and screw 11;

【 B 】 Adjust the thread release bar 9 to 30mm, and lock screw 11;

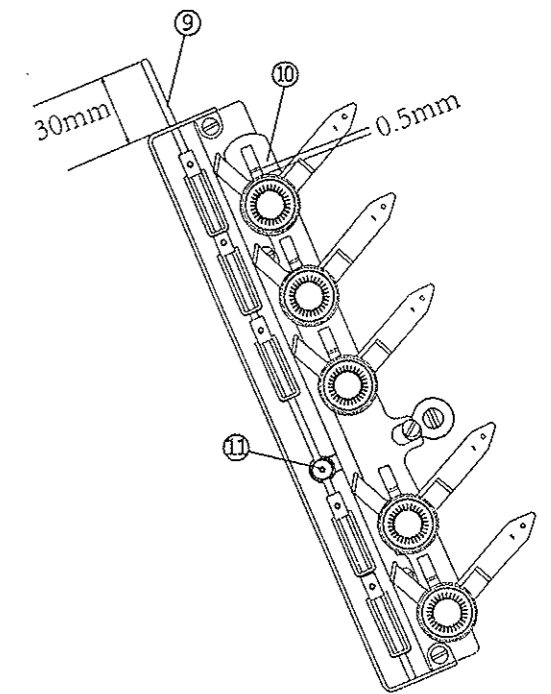

Figure 12

K337D3

INSTALLATION AND ADJUSTMENT

5. Adjustment of motion sensor:

Loosen screw ① adjust the gap between motion sensor ③ (magnetic switch) and magnetic ② to 0.5mm, the distance between arc R and detector is 13mm.

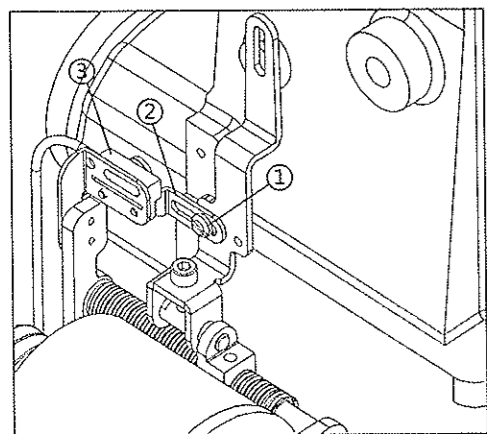
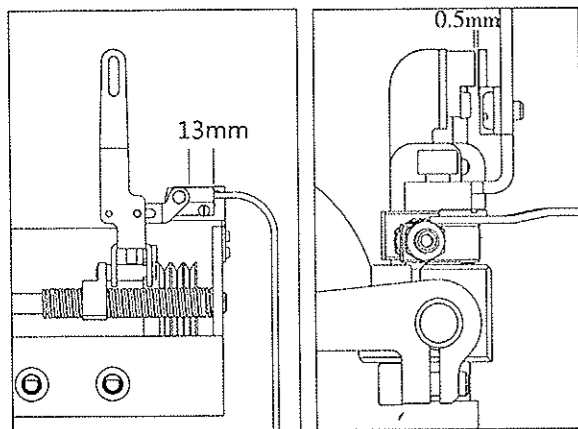

Figure 13

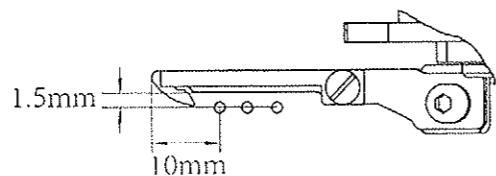
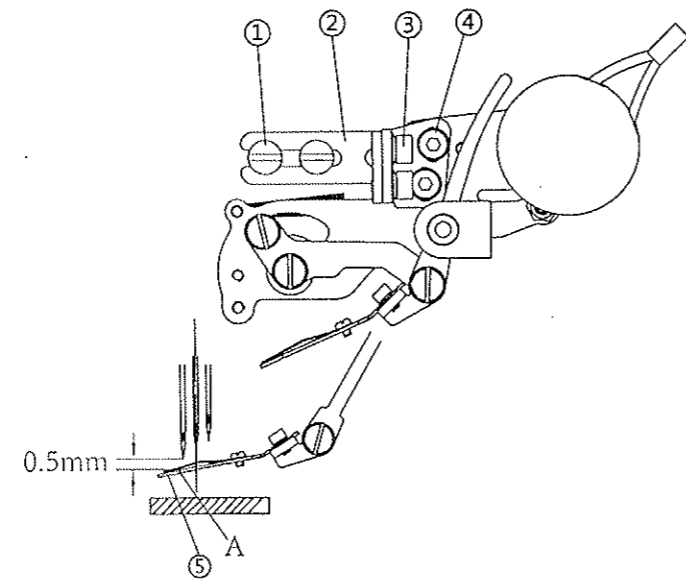

Figure 14

WP

INSTALLATION AND ADJUSTMENT

In case the hook device run into the needle, please raise the needle to the highest position during adjustment.

1. Fix the hook device ② on the machine cover by screw ①.
2. Adjust hook device forward, backward, upward and downward by adjust screw ③, ④.
3. Adjust the position of crochet ⑤ and machine needle according picture 14. When the crochet at the far left position, its distance to the center of left needle is 10mm, the hook of crochet point A at a distance of 0.5mm to the pinpoint of machine needle, the distance between side and center of machine needle is 1.5mm.
4. Locking screw ①, ③, ④ after adjustment.

GK337D3

ST INSTALLATION AND ADJUSTMENT

1. The occlusion between movable knife and fixed knife after cutting thread is 0.5mm;
2. The distance between movable knife and limited point is 15mm when movable knife reach the extreme position of hooking (it means movable knife reach the limited point);
3. After thread cutting, upper decoration thread will be nipped by spring plate ⑤, clamping force is about 0.1kg.f, loosen the nut ③, twist the screw ④.
4. Loosen screw ① ② to adjust the height and left, right position of upper thread cutter.

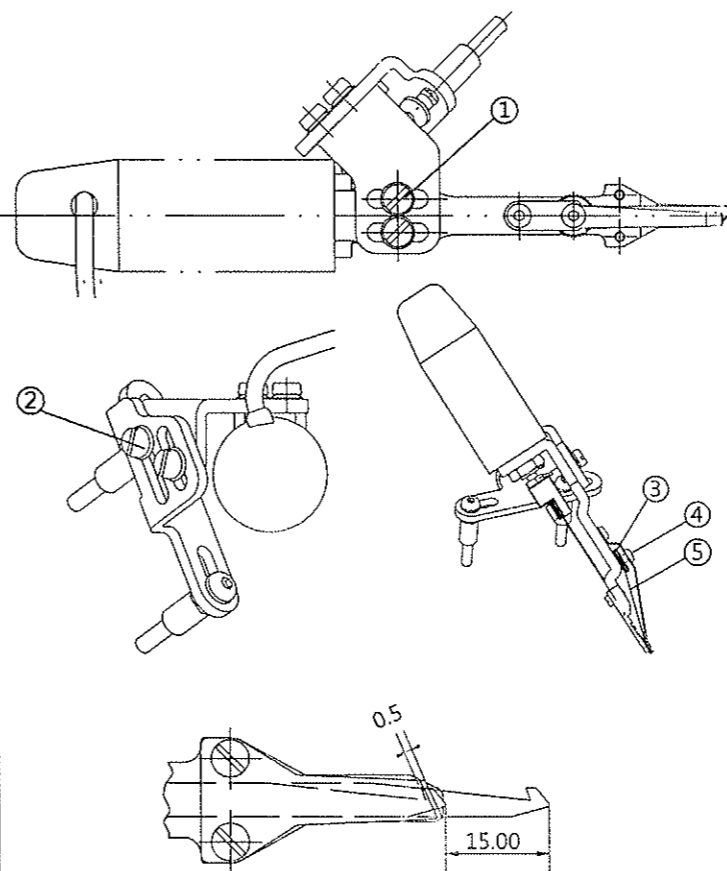

Figure 15

5. The adjustment and checking of upper thread cutter assembly:

[A] Lift the machine needle to the highest point, namely, P point on handwheel take aim at "•" point on the machine cover;

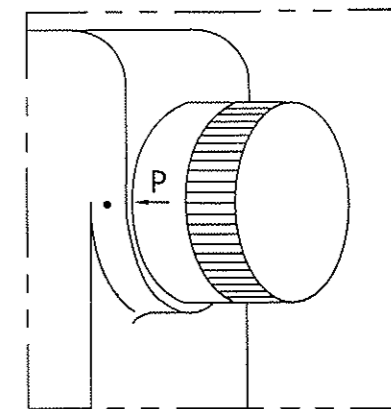

Figure 16

[B] Adjust the stroke of movable knife ⑥ to maximum, about 15mm, the distance between movable knife and left machine needle ⑦ is 0.1-0.5mm, the highness distance between movable knife and presser foot ⑧ is 2-3mm.

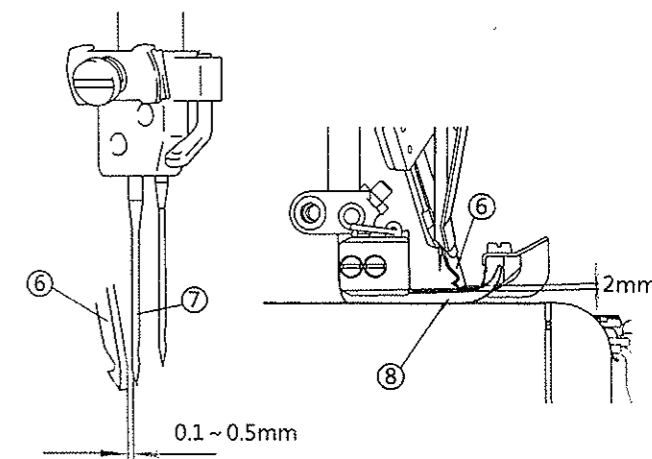

Figure 17

337D3

INSTALLATION AND ADJUSTMENT

1. Fix the electromagnet assembly ③ on machine cover by screw ①, washer ②. Adjust position of electromagnet nut ④ and indenter ⑤, electromagnet drive link move to the lowest position, the height of machine head presser foot lifted about 7mm, locking nut ④.

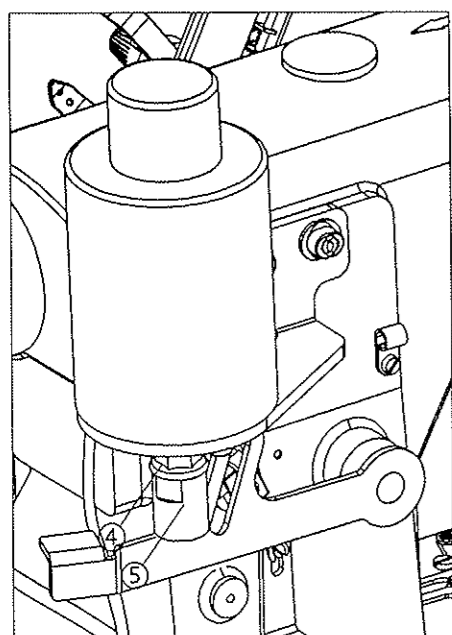
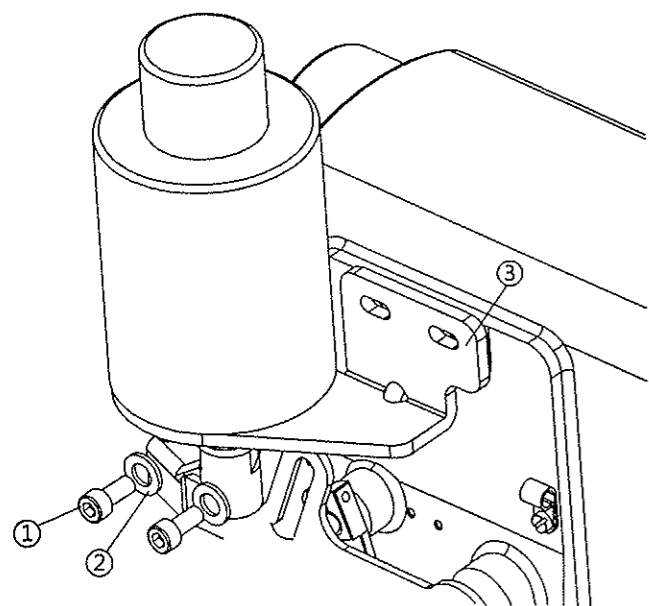

Figure 18

GK337D3

EASY OFF THE NET CORD WINDING CAM EXCLUDE DESCRIPTION

Normal

Looper positioning arrival, four-wire no wound.

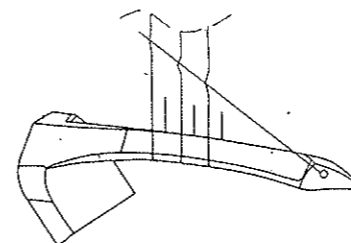

When the movable knife feed, moving knife thread and the bottom line will be separated to locate.

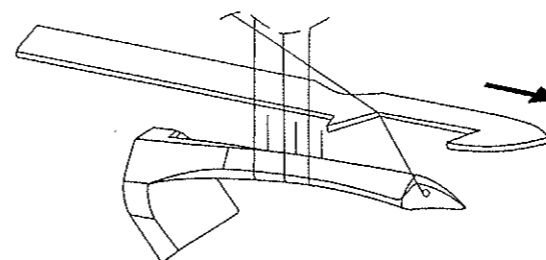

Move knife retraction, when ready cut, the first edge drive the three sewing thread for cutting, a second edge to drive the bottom line were cut move, and with the fixed blade pinching each other bottom line.

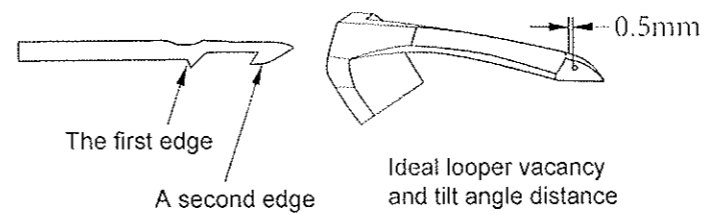
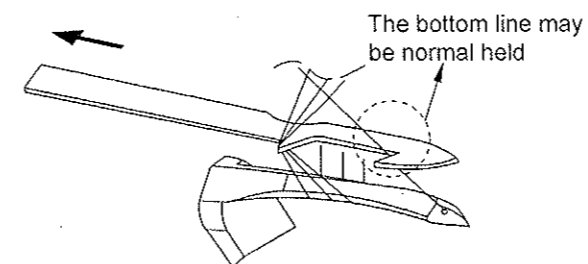

Unusual

When the looper reaches the positioning, the bottom line is pulled to the bottom of the three sewing.

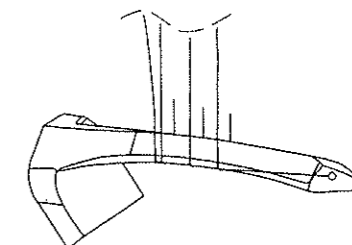

When the movable knife feed, moving knife does not separate the thread and the bottom line to locate.

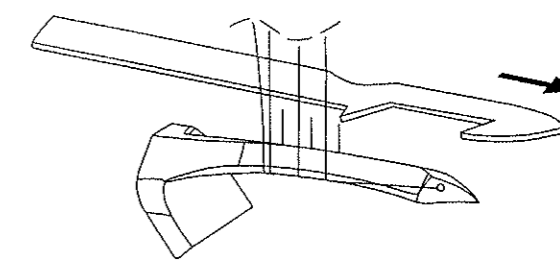

Knife retracts, ready cut, the first cutting edge completely driven by the bottom line of sewing and cutting, forming a second edge no effect occurs and the looper thread can not be clip.

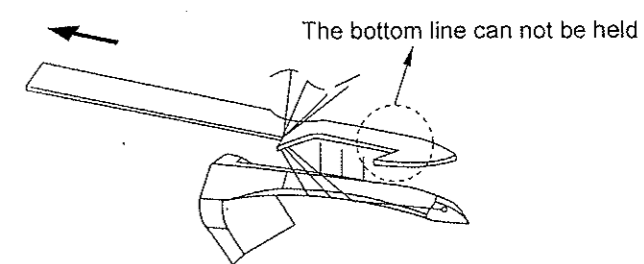

Abnormal

When the looper through thread, the lower thread friction with needle thread, causing the bottom line is drawn, moved below the looper, and can not form the normal position.

GK337D3 UT

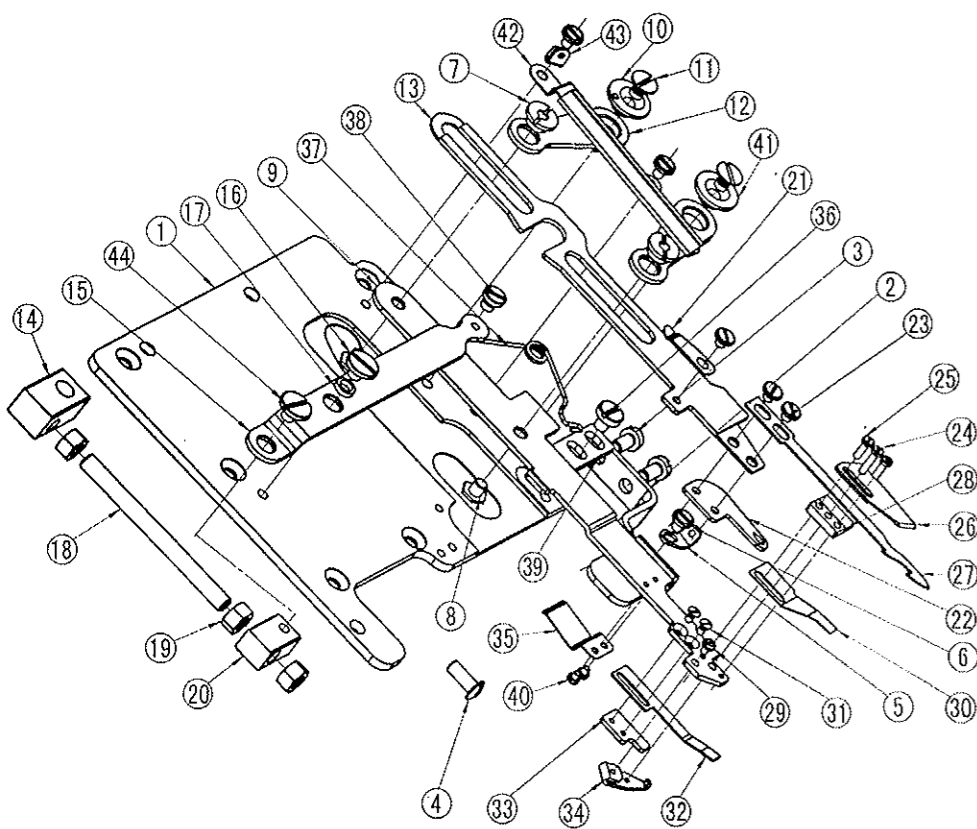
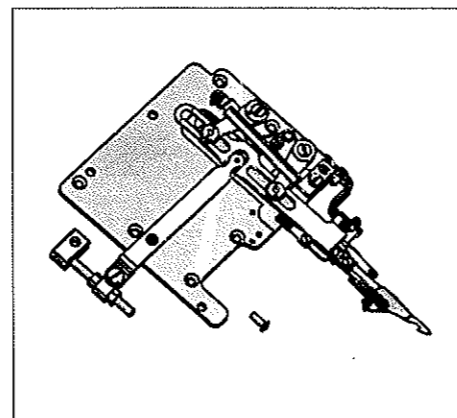

REF.NO	PART NO.	QTY
①	T/GK337EUT-001	1
②	T/GK337EUT-006	1
③	007019A/P	2
④	TE2836	1
⑤	T/GK337EUT-009	1
⑥	TE014-01	3
⑦	Y/VC2700EUTA-003	2
⑧	TE797	2
⑨	KE833A-2	1
⑩	TE1267	1
⑪	TE1268	2
⑫	KE533A-5	2
⑬	KE533-3	1
⑭	Y/VC2700EUT-007	1
⑮	KE533-4	1
⑯	TE1957	1
⑰	TE1125B	1
⑱	GB/T77-M5x50-45H-FH	1
⑲	GB/T6170-M5-6-FH	3
⑳	Y/VC2700EUT-006	1
㉑	KE533-13	1
㉒	GK337EUTA-002	1
㉓	TE1273	3
㉔	TE1274	1
㉕	TE1275	2
㉖	KE533-17	1
㉗	KE533-16	1
㉘	KE533-14	1
㉙	TE702	1
㉚	KE533-9	1
㉛	SM250/S	2
㉜	KE533-8	1
㉝	KE533-12	1
㉞	KE533-11	1
㉟	T/GK337EUT-008	1
㊱	TE2622	1
㊲	TE1270	1
㊳	TE1269	1
㊴	T/GK337EUT-007	1
㊵	TE805	2
㊶	TE1271	1
㊷	T/GK337EUT-003	1
㊸	T/GK370EUT-004	1
㊹	TE1299/P	1

GK337D3 WP

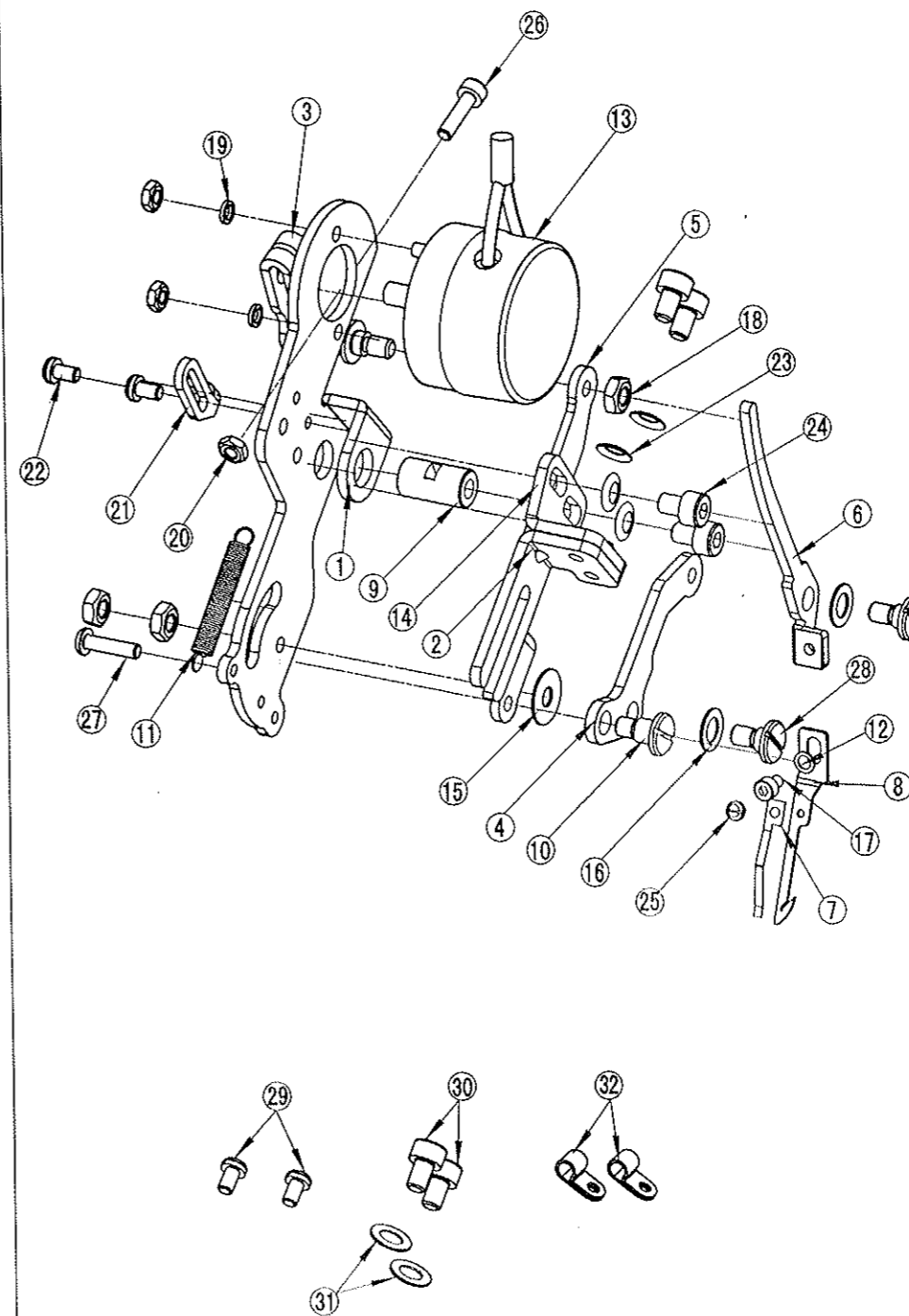
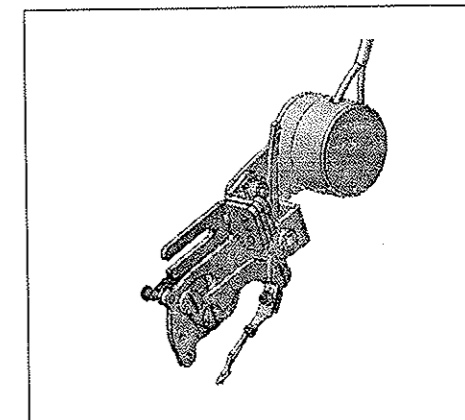

REFNO	PART NO.	QTY
①	P/W600EWPC-001	1
②	P/W600EWPC-003	1
③	P/W600EWPC-004	1
④	P/W600EWPC-005	1
⑤	P/W600EWPC-007	1
⑥	P/W600EWPC-008	1
⑦	P/W600EWPC-009	1
⑧	P/W600EWPB-010	1
⑨	P/W600EWPC-011	1
⑩	TE2119	1
⑪	P/W600EWPC-014	1
⑫	GB/T848-3-140HV-Zn-B	1
⑬	TE2144	1
⑭	P/W600EWPC-002	1
⑮	P/W600EWPC-018	1
⑯	P/W600EWPC-015	2
⑰	GB/T70.1-M3*4-12.9-FH	1
⑱	GB/T6170-M4-10-FH	4
⑲	GB/T93-3-65Mn-FH	2
⑳	GB/T6170-M3-8-FH	3
㉑	P/W600EWPC-006	1
㉒	SM330/S	2
㉓	GB/T1972.B-8-FH	4
㉔	GB/T70.1-M4*6-12.9-FH	4
㉕	TE805	1
㉖	GB/T70.2-M3*12-12.9-FH	1
㉗	P/W600EWP-016	1
㉘	TE2118	3
㉙	007017A/P	2
㉚	GB/T70.1-M*10-12.9-FH	2
㉛	GB/T97.1-4-140HV-FH	2
㉜	ACC-2	2

K337D3
T

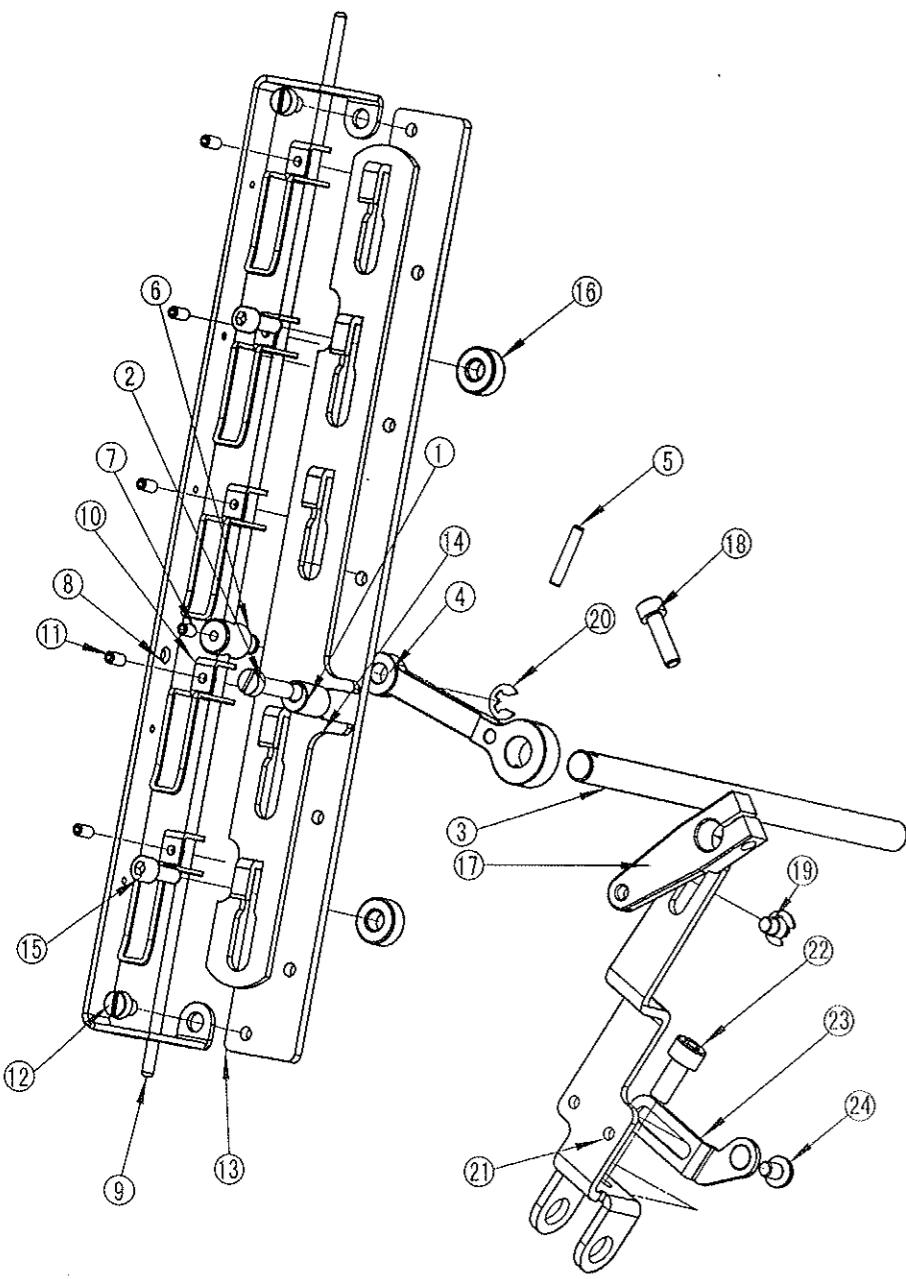

REF.NO	PART NO.	QTY
①	Y/VC2700ETT-007-3	1
②	GB/T823-M4*16-12.9-FH	1
③	Y/VC2700ETT-007-2-2	1
④	Y/VC2700ETT-007-2-1	1
⑤	GB/T879.1-3*16	1
⑥	Y/VC2700ETT-007-1	1
⑦	GB/T77-M3*4-45H-FH	1
⑧	Y/VC2700ETT-003	1
⑨	Y/VC2700ETT-002	1
⑩	Y/VC2700ETT-006	5
⑪	GB/T77-M3*6-45H-FH	5
⑫	TE806/P	2
⑬	Y/VC2700ETT-004	1
⑭	T/GK370ETT-001/T	1
⑮	GB/T70.1-M4*14-12.9-FH	2
⑯	Y/VC2700ETT-001	2
⑰	Y/VC2700ETT-008-1	1
⑱	GB/T70.1-M4*14-12.9-FH	1
⑲	TE1897	1
⑳	GB/T896-4-65Mn-FH	2
㉑	Y/VC2700ETT-008-2	1
㉒	GB/T70.1-M5*14-12.9-FH	1
㉓	Y/VC2700ETT-008-3	1
㉔	TE806/P	1

GK337D3
DD

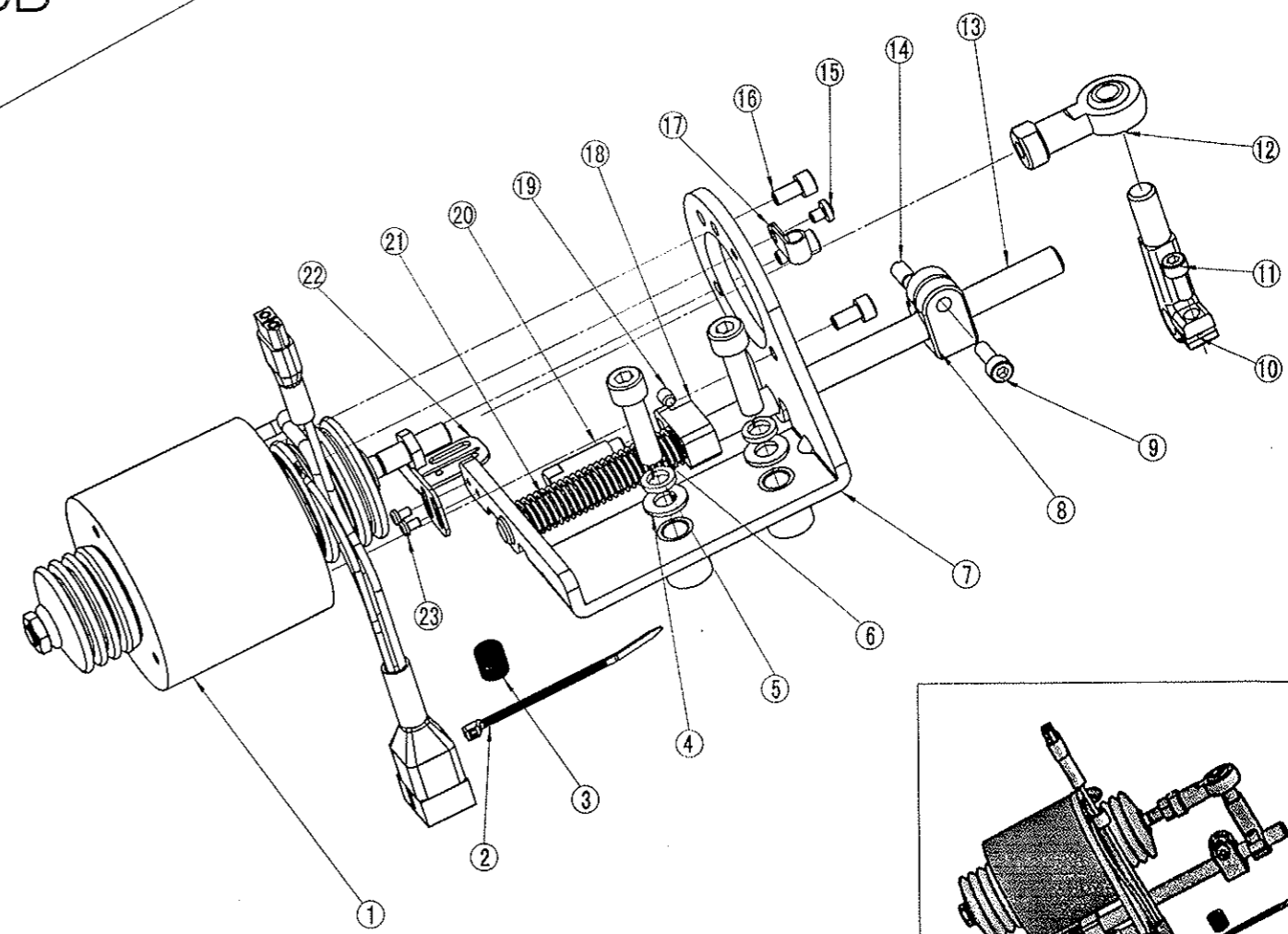

REF.NO	PART NO.	QTY
①	TE2275	1
②	ALT-085S-B	1
③	P/W600PUTA-001-007	1
④	GB/T97.1-6-140HV-Zn-B	2
⑤	GB/T93-6-65Mn-FH	2
⑥	GB/T70.1-M6*20-12.9-FH	2
⑦	Y/VC2700EDDA-001	1
⑧	Y/VC2700EDD-009	1
⑨	GB/T70.1-M5*14-12.9-FH	1
⑩	Y/VC2700EDD-004	1
⑪	GB/T70.1-M5*12-12.9-FH	1
⑫	Y/VC2700EDD-003	1
⑬	Y/VC2700EDD-007	1
⑭	TE1905	1
⑮	007018A/P	1
⑯	GB/T70.1-M5*10-12.9-FH	3
⑰	ACC-2.5	1
⑱	Y/VC2700EDD-002-1	1
⑲	GB/T77-M5*5-45H-FH	1
㉑	Y/VC2700EDD-002-2	1
㉑	P/W600PUTA-001-012	1
㉒	Y/VC2700EDD-008	1
㉓	SM331	1

GK337D3
LFE

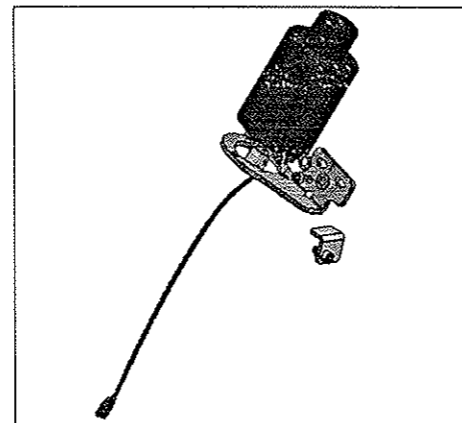
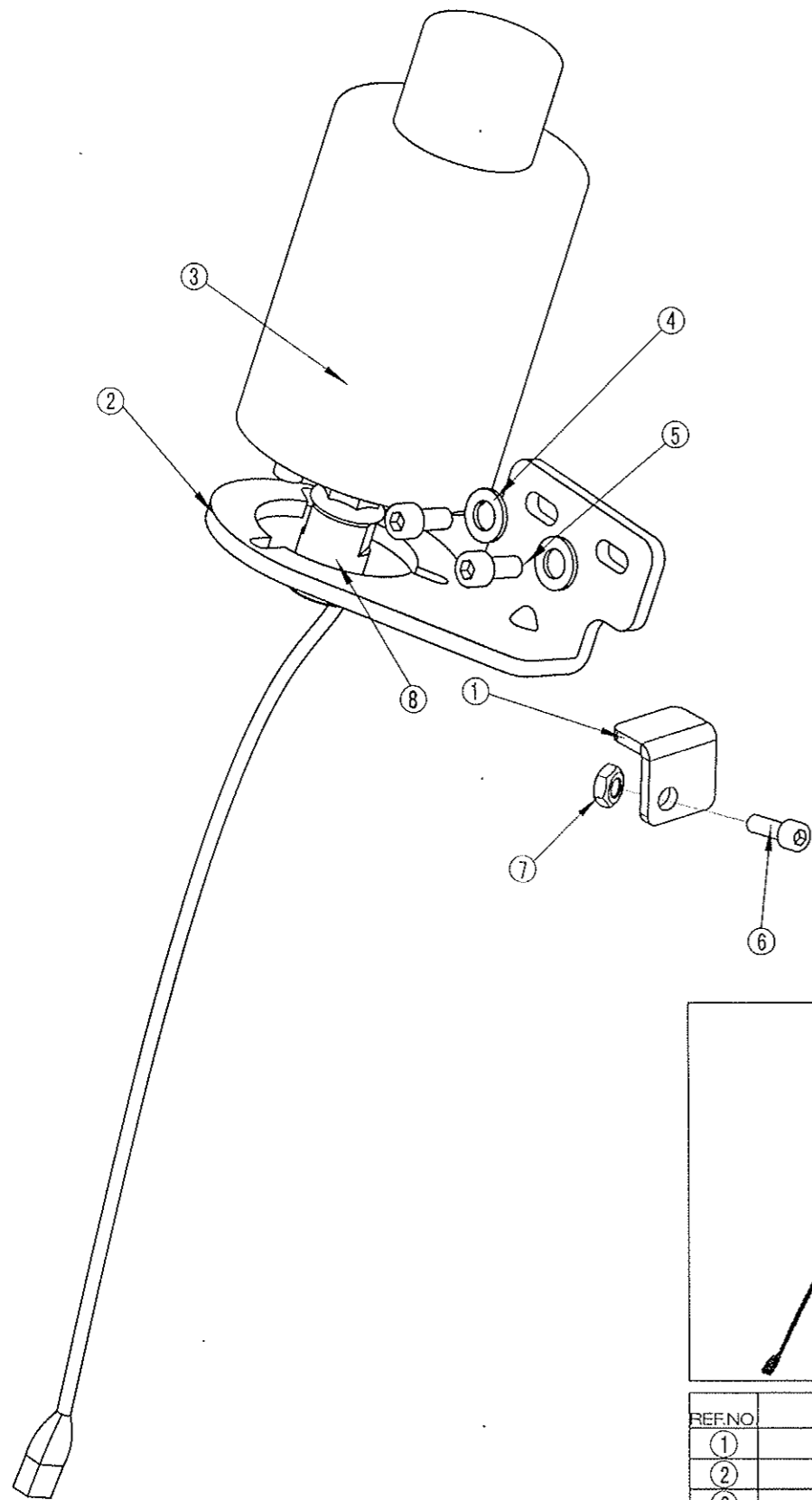

REF.NO	PART NO.	QTY
①	T/GK337ELFE-001	1
②	Y/VC2700ELFE-001	1
③	TE2274.A	1
④	GB/T97.1-6-140HV-Zn-B	2
⑤	GB/T70.1-M6*16-12.9-FH-A	2
⑥	GB/T70.1-M5*12-12.9-FH	1
⑦	GB/T6170-M5-6-FH	1
⑧	TE2963A	1

GK337D3
ST

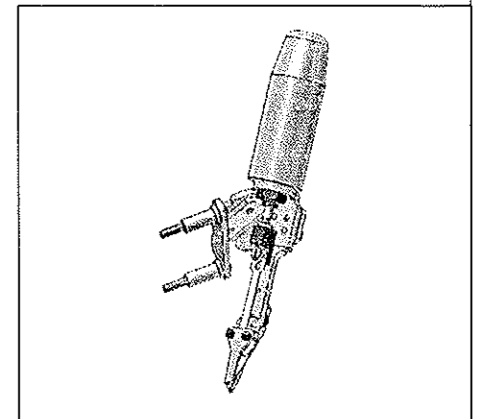
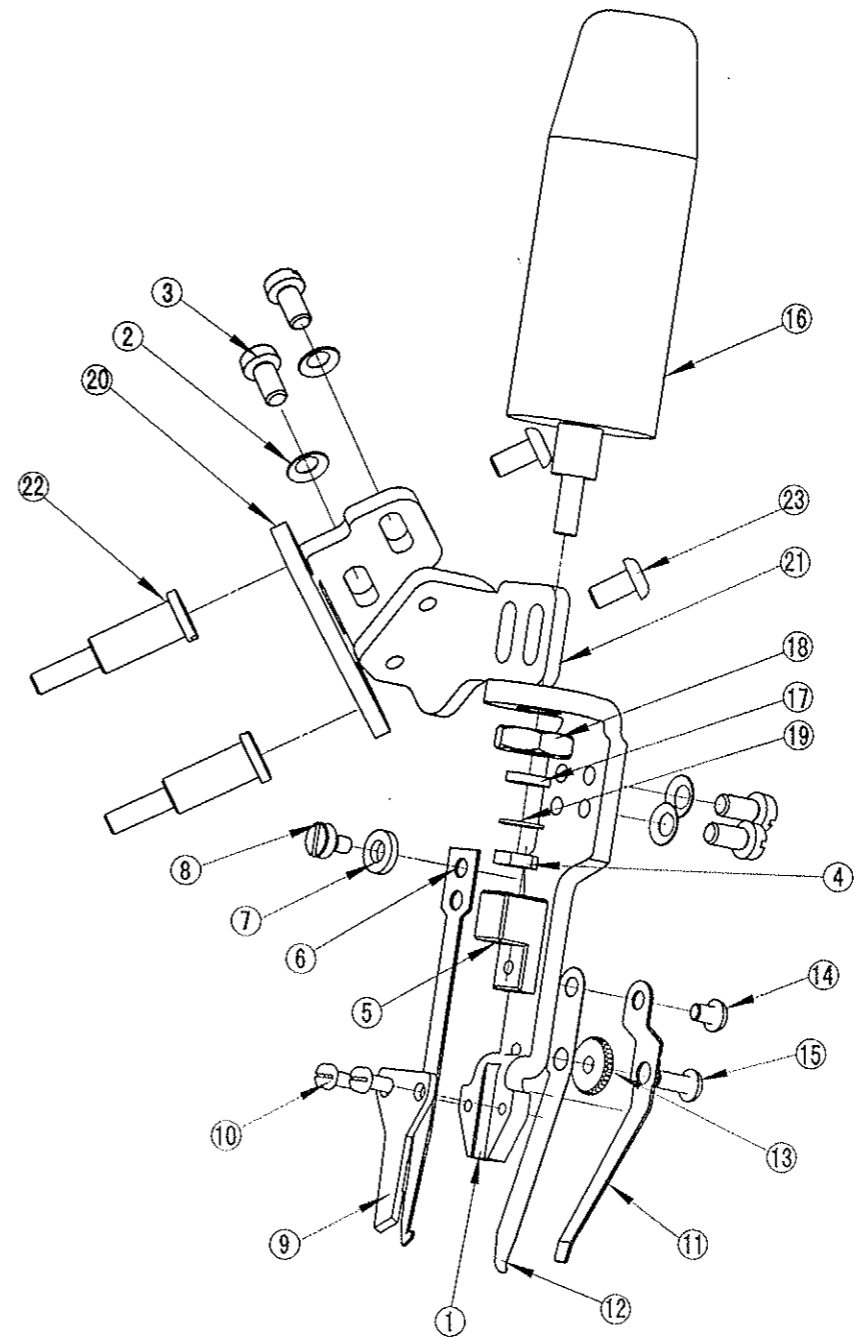

REFNO	PART NO.	QTY
①	P/W600ESTA-001	1
②	GB/T1972. B-8-FH	4
③	P/W600PST-010	4
④	TE3353-4	1
⑤	P/W600PSTA-008	1
⑥	P/W600PST-004	1
⑦	P/W600PST-006	1
⑧	TE1513	1
⑨	P/W600PST-005	1
⑩	TE1512	2
⑪	KE233	1
⑫	KE232. A	1
⑬	P/W600EST-018	1
⑭	GB/T70.1-M3*4-12.9-FH	1
⑮	GB/T70.2-M3*8-12.9-FH	1
⑯	TE3353	1
⑰	TE3353-1	1
⑱	TE3353-2	1
⑲	TE3353-3	1
⑳	P/W600ESTB-003	1
㉑	P/W600ESTA-002	1
㉒	TE1004	2
㉓	GB/T70.2-M4*8-12.9-FH	2