



TYPICAL

GC20665-D2T3

**1-NEEDLE COMPOUND FEED LOCKSTITCH SEWING
MACHINE WITH AUTO-TRIMMER**

OPERATION INSTRUCTION / PARTS MANUAL

- Please don't adjust and repair the machine by non-professionals, except adjusting stitch.
- Specifications subject to change without notice

TYPICAL SEWING MACHINE WANPING MACHINERY CO.,LTD.

ADD: WANPING TOWN, WUJIANG CITY, JIANGSU

PROVINCE, CHINA

TEL: +86-512-63391278

FAX: +86-512-63391371

POST. CODE: 215223

[Http://www.typicalwpchina.com](http://www.typicalwpchina.com)

E-mail: export@typicalwpchina.cn

CONTENTS

Operation Instruction

1. Brief introduction.....	1
2. Main specifications.....	1
3. Machine installation.....	1
4. Setting the waste oil collector.....	2
5. Tension of belt.....	2
6. Installing the belt cover.....	2
7. Lubrication.....	3
8. Cleaning the small oil pan.....	4
9. Setting the needle.....	4
10. Threading the bobbin thread.....	5
11. Installing the thread tension for bobbin thread winder.....	5
12. Winding bobbin thread.....	5
13. Threading the needle thread.....	6
14. Stitch length.....	6
15. Thread tension.....	6
16. Adjusting thread take-up spring.....	7
17. Presser foot lift.....	7
18. Pressure of presser foot.....	7
19. Adjusting needle guard plate.....	7
20. Reset of safety clutch.....	8
21. Adjusting hook thread opener.....	8
22. Timing between needle and rotating hook.....	8
23. Alternating lift amount of presser feet.....	9
24. Adjusting the cutter.....	9
25. Stop position.....	9
26. Settings for different speeds.....	10
27. Troubleshooting.....	10

Parts Manual

1. Casting mechanism.....	11-14
2. Arm shaft & thread take-up mechanism.....	15-18
3. Needle bar rocking frame mechanism.....	19-20
4. Upper feed mechanism.....	21-24
5. Lower feed and reverse regulating.....	25-28
6. Lower shaft and rotating hook.....	29-30
7. Thread tension components.....	31-32
8. Bobbin winder & tension components.....	33-34
9. Thread trimming mechanism.....	35-38
10. Auto-reverse feed mechanism.....	39-40
11. Tension release mechanism.....	41
12. Auto-lifter mechanism.....	42
13. Lubrication components.....	43-46
14. Accessories.....	47-50

Operation Instruction

1. Brief introduction

This compound feed sewing machine is designed with unique feed mechanisms, which make sewing of uneven and thick materials easily. Smooth, uniform and neat stitches are promised. The machine runs with high speed and low noise thanks for its' vertical-axis rotating hook, sliding lever take-up and synchronized belt driven mechanisms. It is designed for sewing of car seats, sofas, leather bags and tents industry.

3. Machine installation (Fig.1)

1. Setting of hinges and cushions of machine head

Fix hinges ① and rubber cushions ② into the working table by nails ③.

2. Setting of oil pan

Fix oil pan ④ under the working table by 8 wooden screws as per illustration.

2. Main specifications

Applications	Medium & heavy weight materials
Max sewing speed	2500 s.p.m
Max stitch length	9mm
Needle bar stroke	36mm
Needle	DP×17(Nm125~Nm180) 23#
Lubrication	Oil wick (Rotating hook self oiled)
Rotating hook	Self-oiled big rotating hook
Presser foot lift height	9mm by hand, 16mm by knee/lifter
Motor power	Servo motor

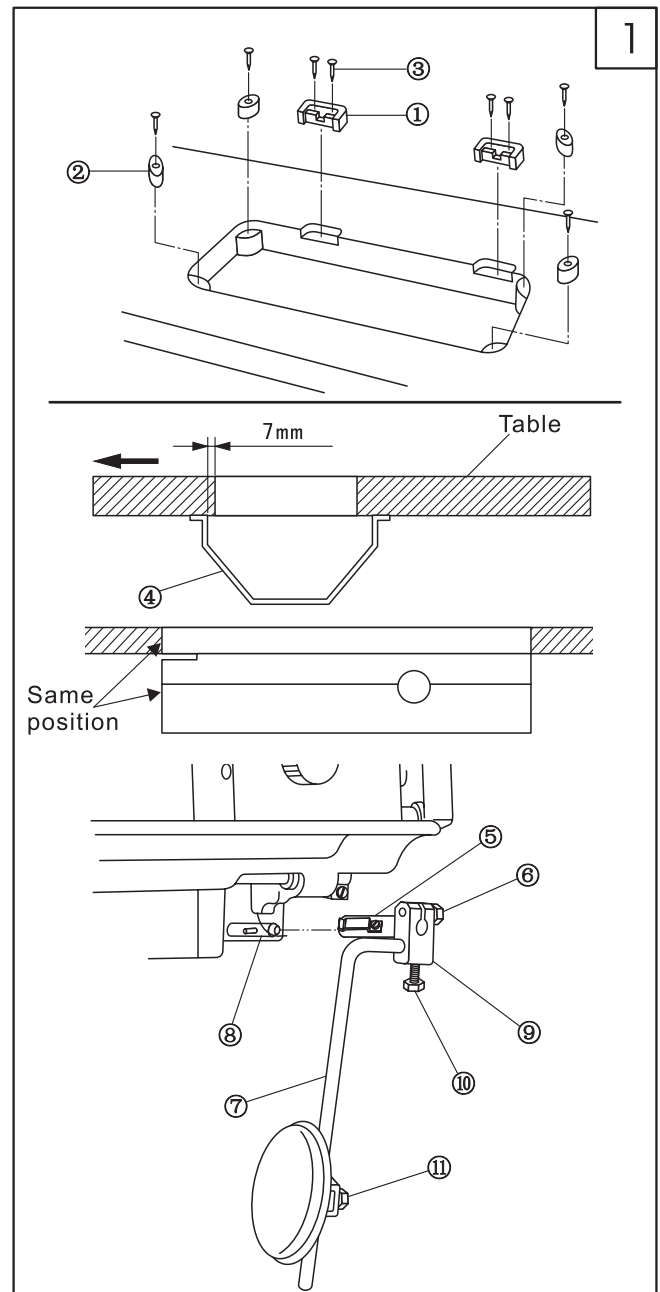

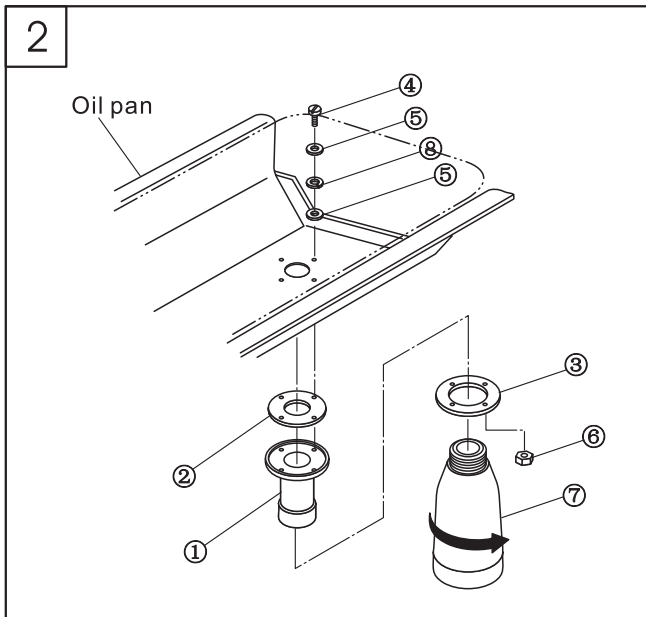

4. Setting the waste oil collector (Fig.2)

1. Install oil bolt ①, oil seal ② and washer ③ to the oil pan. Put spacer ⑤, washer ⑧ onto screw ④ and fix them with screw ⑥.
2. Screw oil pot ⑦ up to the oil bolt ①.

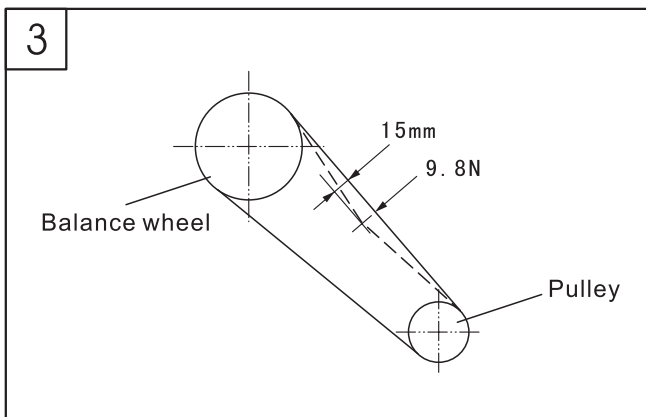

5. Tension of belt (Fig.3)

Adjust the height of motor to regulate the tension of belt. Press the center of belt with a force of 9.8N, displacement should be 15mm, that means tension is proper.

Note: Turn off the power and make sure the motor stopped before adjustment.

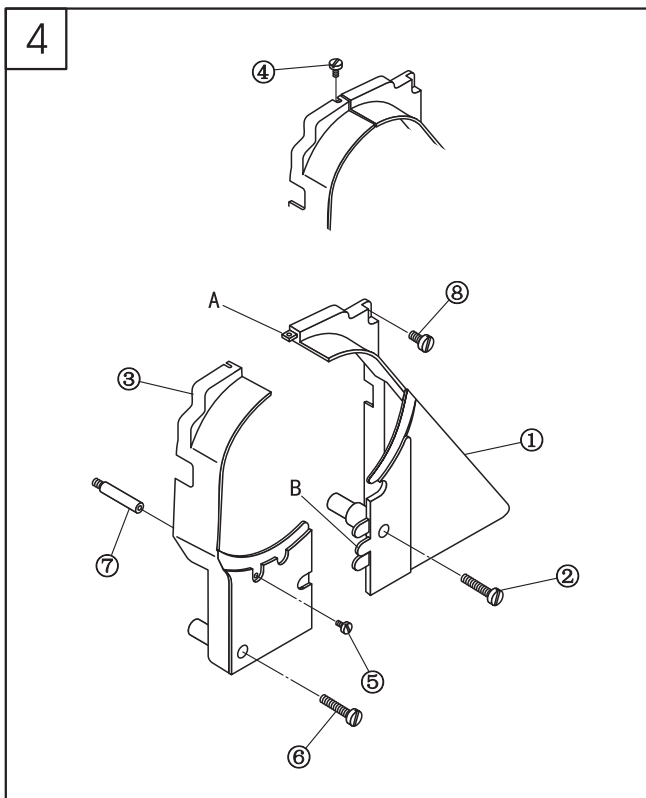

6. Installing the belt cover (Fig.4)

1. Screw the belt cover supporting pole into the screw hole.
2. Install belt cover (R) ① to the machine head by setscrew ② and ⑧.
3. Set belt cover (L) ③ to the pawl A and B of cover ①.
4. Fix belt cover (L) ③ by set screw ④, ⑤ and ⑥.

Note: After installation, make sure the belt cover is not touched with the belt and handwheel.

7. Lubrication (Fig.5)

1. Lubrication in the face plate

- 1). Remove face plate screw.
- 2). Open face plate ① as per illustration.
- 3). Drip oils to positions signed by arrows.
- 4). Close the face plate.
- 5). Tighten the screw.

2. Lubrication in the arm

- 1). Drip oils to the signed position by arrows everyday.
- 2). Oil the machine before its Initial running or after a long time idle at signed point and, remove top cover ②, drip oils to all felts and wicks inside the arm.

3. Small oil pan

- 1). Insert small oil pan ③ into the oil pan, with the projecting position into the waste oil hole.
- 2). Insert oil tube ④ into filter ⑤ in the small oil pan and fasten by clip.
- 3). Fill oil into small oil pan to the mark of HIGH.
- 4). Replenish oil in time when oil level is below LOW mark.
- 5). Run the sewing machine after oil filled, oil movement should be viewed from the oil window C. (Speed should be over 1500rpm)

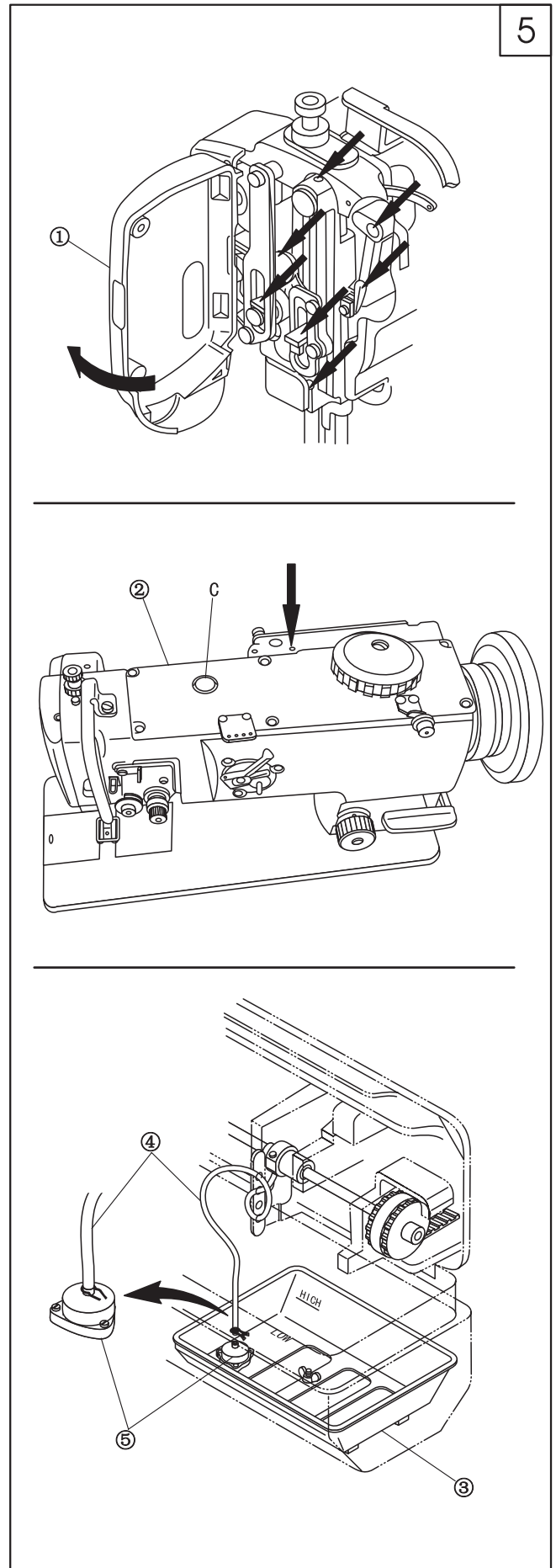

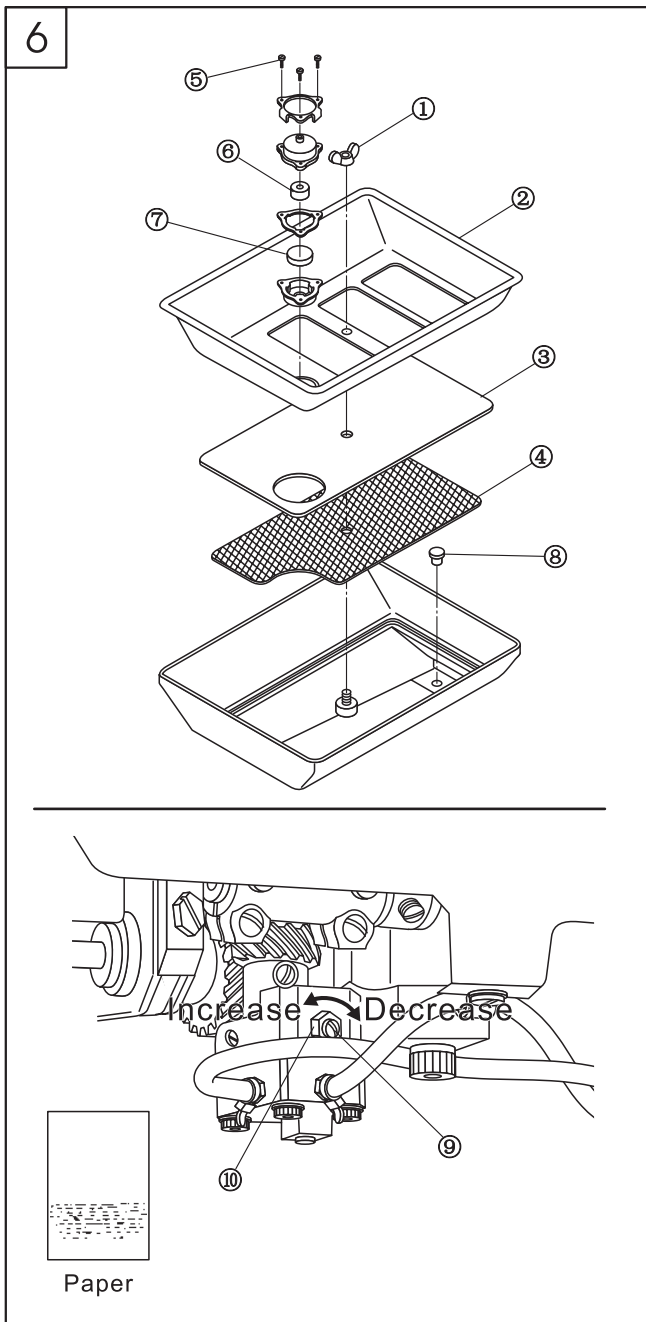

8. Cleaning the small oil pan (Fig.6)

- 1.Remove oil tube off the small oil pan.
- 2.Take off wing nut ①, tray ②, filter ③ and supporter ④, clean the small oil pan.
- 3.Remove screw ⑤, clean filter element ⑥ and magnet ⑦.
- 4.Take off plug ⑧ from small oil pan to drain waste oil and insert the plug ⑧ after drained. (Note: Oil should be drained first before taking out the small oil pan.)
- 5.Put filter element ⑥ and magnet ⑦ into the case and fix on the tray ② with screw ⑤.
- 6.Then put supporter ④, filter ③ and tray ② in reverse sequence, fix them with swing nut ① on the small oil pan.
- 7.Insert oil tube into the filter and fix with clip.

- 8.Loosen nut ⑩, to regulate oil of rotating hook by turning screw ⑨. Turn clockwise to reduce oil amount, turn counterclockwise to increase oil amount.
- 9.Hold a paper strip close to the rotating hook for 5 seconds, if oil sprays as in the illustration shows, the proper oil amount is acquired.

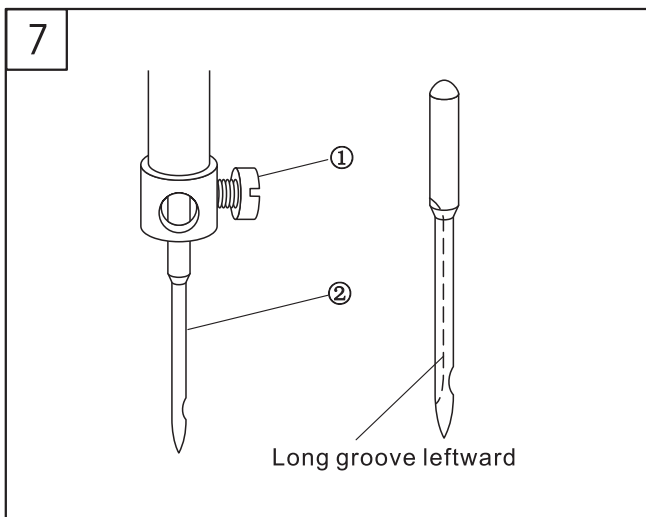

9. Setting the needle (Fig.7)

- 1.Turn the handwheel to raise the needle bar to its highest point.
- 2.Loosen needle set screw ② and have the long groove of the needle ① face leftward.
- 3.Insert needle fully.
- 4.Tighten the set screw ②.

10. Threading the bobbin (Fig.8)

- 1.Lift the latch ① and take out the bobbin.
- 2.Insert bobbin correctly and close the latch.
- 3.Draw bobbin thread through slot ②, tension spring and hole ③.
- 4.Bobbin should turn in the direction shown by the arrow when draw the bobbin thread.

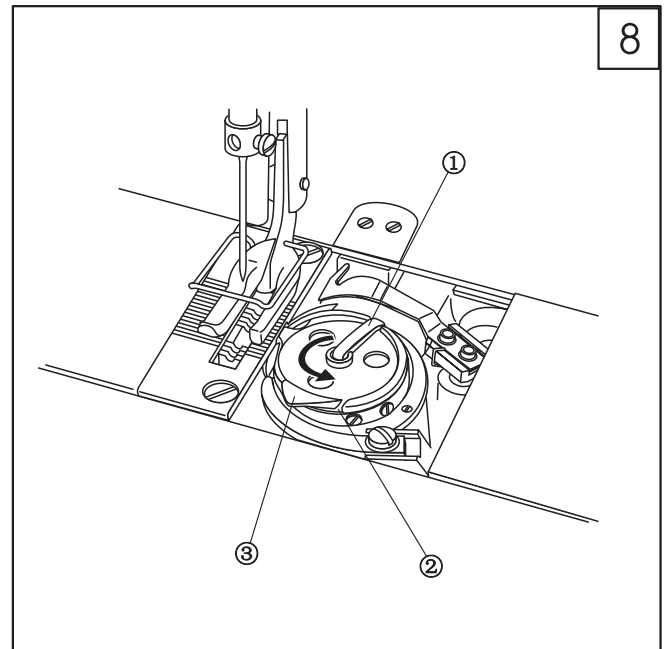

11. Installing the thread tension for bobbin thread winder(Fig.9)

Mount thread tension ① onto the top cover with set screw ②.

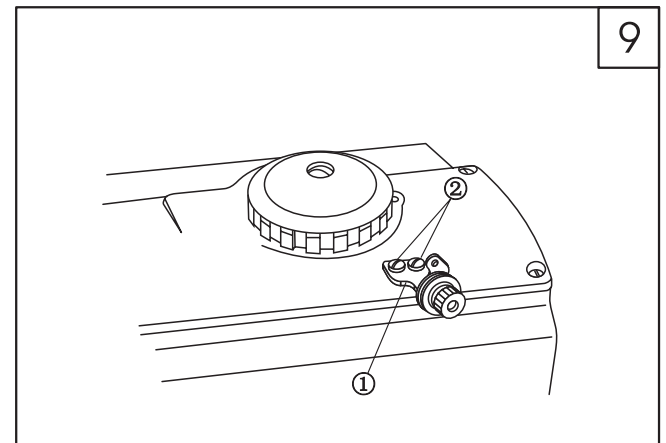

12. Winding bobbin thread (Fig.10)

- 1.Thread in sequence ① ~④, then wind thread around the bobbin several circles
- 2.Press latch A.
- 3.Loosen screw B to adjust the latch to get the proper thread amount of 80% of the bobbin capacity.
- 4.If thread wound unevenly, move guide C to regulate and fasten with screw D.
- 5.If the proper thread amount acquired, the latch will disengage automatically.

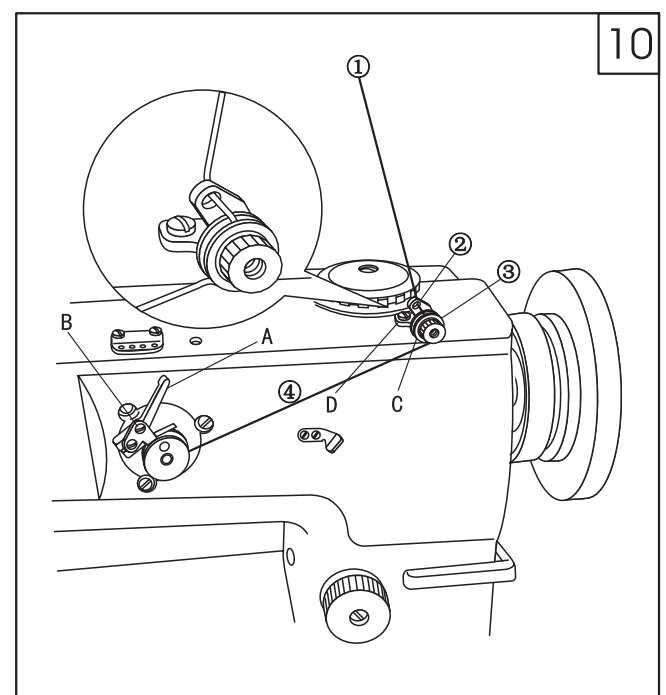

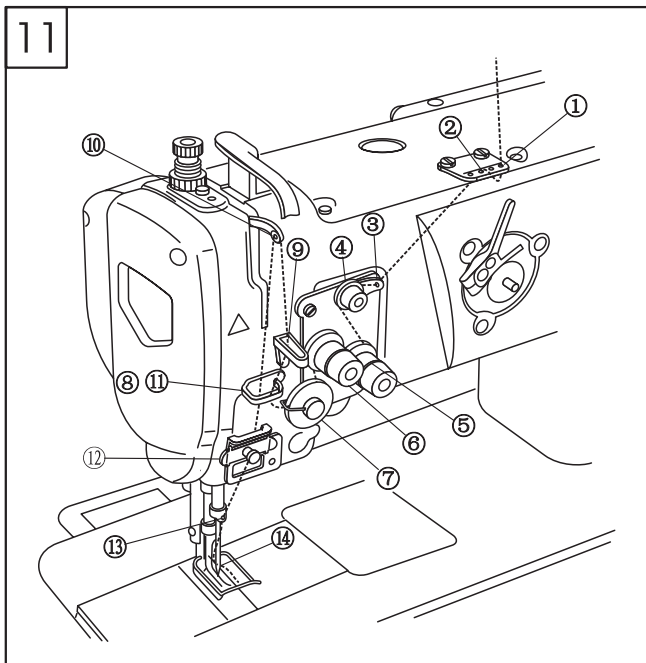

13. Threading the needle thread(Fig.11)

Thread in sequence as shown in the illustration.

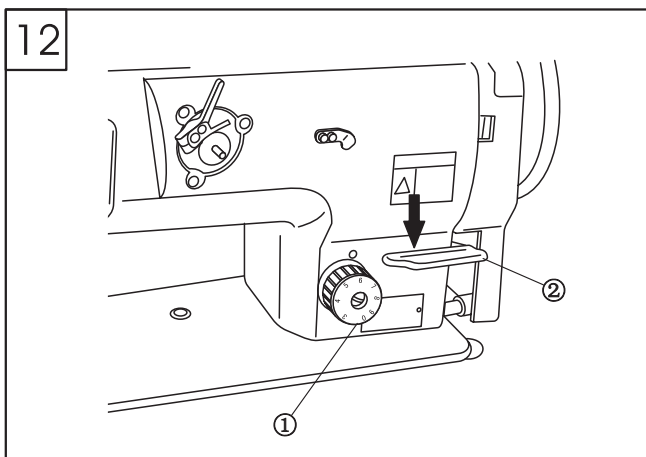

14. Stitch length (Fig.12)

Turn the stitch dial ① leftward or rightward to get your required stitch length.
Press the reverse lever ② to start reverse sewing, loose it to restore normal sewing.

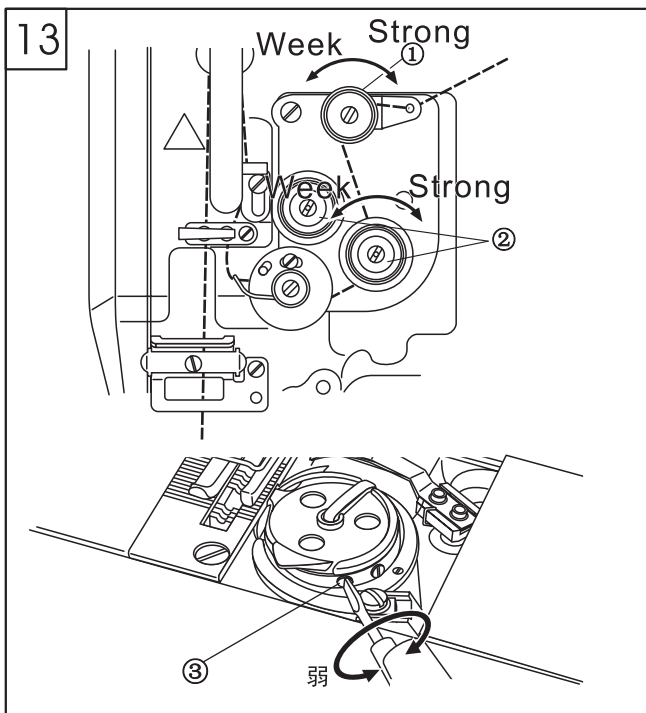

15. Thread tension (Fig.13)

1. Tension of needle thread

Turn the tension nut ① clockwise to short the thread remains after cut, turn counterclockwise to lengthen the thread remains.

Turn the tension nut ② clockwise to increase needle thread tension, turn counterclockwise to reduce the tension.

2. Tension of bobbin thread

Turn the tension nut ③ clockwise to increase bobbin thread tension, turn counterclockwise to reduce the tension.

16. Adjusting thread take-up spring (Fig.14)

- 1.To change the take-up spring swing range
a.Loosen set screw ② and move plate ③ to adjust the take-up spring.
b.Move plate ③ rightward to increase take-up spring swing range, move leftward to reduce swing range.
- 2.To change the tension of take-up spring
Loosen nut ④, turn shaft ⑤ counterclockwise to increase tension, turn clockwise to reduce the tension.

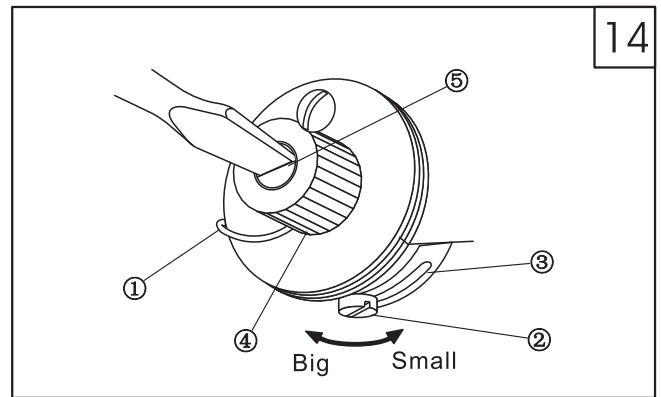

17. Presser foot lift (Fig.15)

- 1.When the presser foot on the lower resting position, raise the foot lift lever ① as illustration. The presser foot rises 9mm then stop.
- 2.Lower the lift lever ① to restore the presser foot.

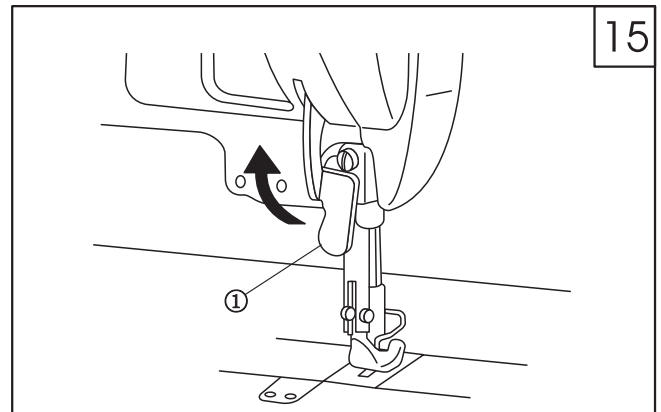

18. Pressure of presser foot (Fig.16)

Turn the regulating bolt ① rightward to increase the pressure, turn counterclockwise to reduce the pressure. Tighten nut ② after adjustment.

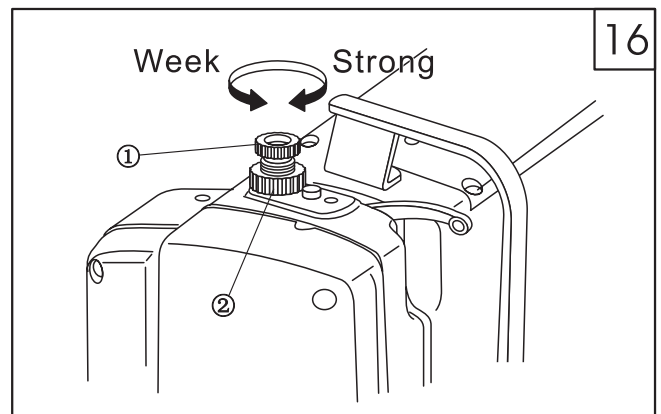

19. Adjusting needle guard plate (Fig.17)

Check the position of needle guard plate after change the rotating hook. The standard position of the guard plate ② is 0.1~0.2mm against needle ①. If the clearance is not right, bend the guard plate to adjust.

- 1.To bend the guard plate inward, insert a screwdriver outside.
- 2.To bend the guard plate outward, insert a screwdriver inside of the plate.

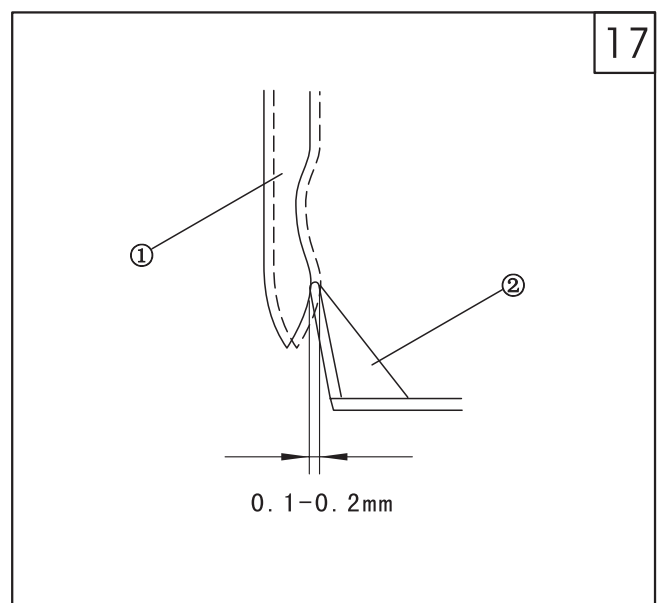

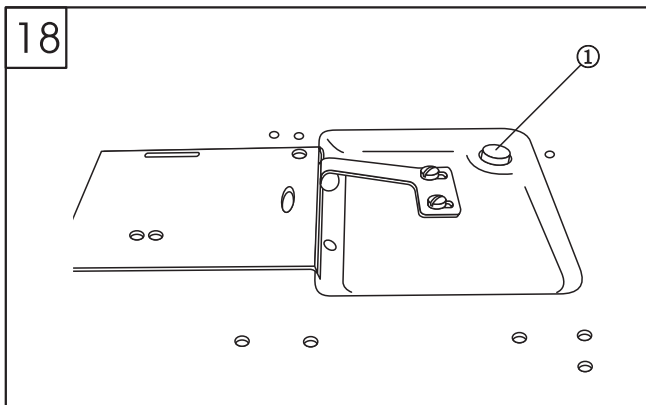

20. Reset of safety clutch (Fig.18)

In case the rotating hook is applied with a over strong force during operation, the safety clutch start working. The rotating hook stop turn even the handwheel is still turning. Check the machine and solve the problem, then reset the safety clutch.

1. Press button ① down on the bed, Firmly turn the handwheel reversely at the same time.
2. When a “click” sound is heard, the safety clutch is reset successfully.

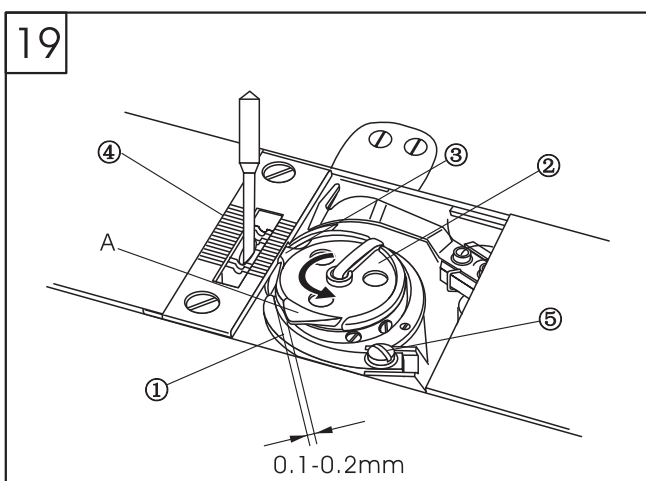

21. Adjusting hook thread opener (Fig.19)

1. Turn the handwheel in normal direction to move the thread opener ① to its ultimate position.
2. Turn the bobbin body ② in direction showed by arrow, to make stopper ③ (the projection part) against the notch under the bottom of the needle plate ④.
3. Adjust the clearance between horn A and the opener to 0.1~0.2mm, tighten the set screw ⑤.

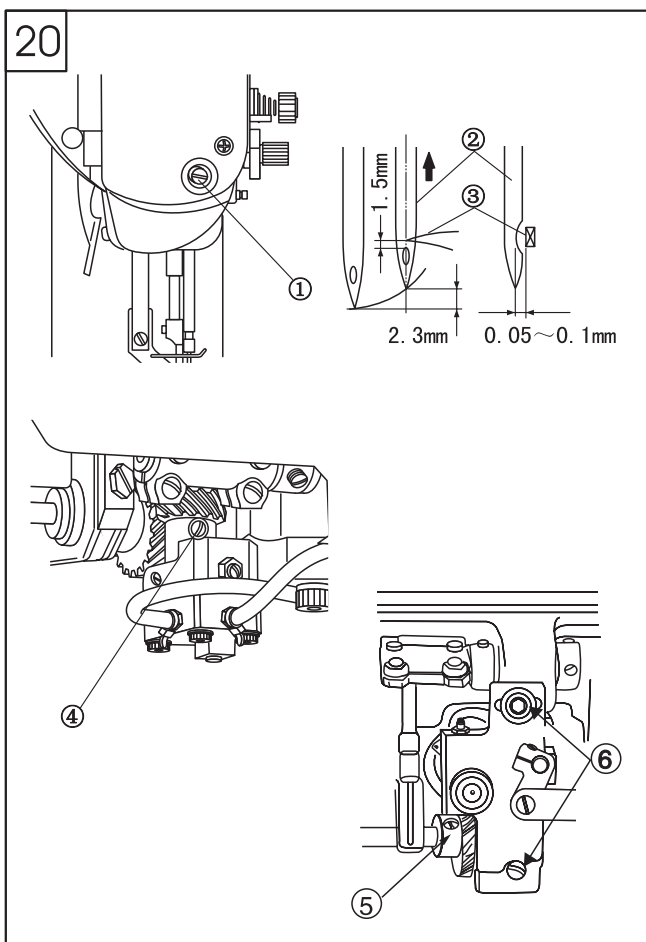

22. Timing between needle and rotating hook (Fig.20)

1. Turn the stitch dial to 0.
2. Turn the handwheel to raise needle bar by 2.3mm from its lowest point. Loosen needle bar joint screw ①, adjust the clearance between top of the needle hole and hoop tip to 1.5mm. Tighten screw ①.
3. Turn the handwheel to raise needle bar by 2.3mm from its lowest point. Adjust the hook tip ③ align with the center of the needle ② axis. Tighten the gear (small) two set screws ④, make sure that the first V-screw of two set screws align with the V-notch on the hook shaft.
4. When hook tip ③ aligned with the center of the needle ② axis, loosen the set screw ⑥ and move the hook saddle leftward or rightward to make the clearance between hook tip and needle to 0.05~0.1mm. Tighten screw ⑥.
5. Loosen the gear (big) two set screws ⑤, move gear (big) leftward or rightward to make the hook tip ③ align with the center of the needle ② axis. Tighten set screws ⑤, make sure that the first screw of two set screws aligns with the flat notch of the lower shaft.

23. Alternating lift amount of presser feet (Fig.21)

To adjust the lift amount of presser feet by moving upper feed crank ① up or down within the range of the long slot. Move the crank up to increase alternating lift amount, move down to reduce. Tighten nut ③ after adjusting.

In case the lift amount of the two presser feet is different, move the two feet to align with the needle plate surface, loosen crank set screw ②. Turn the handwheel in normal direction, the lift amount of outer foot is much than that of inner foot. Turn the handwheel reverse, the lift amount of outer foot is less than that of inner foot. Tighten screw ② after adjustment.

Remove the right side of the window plate, the upper feed crank ① can be observed.

Presser feet alternating lift amount	
Mark A	5mm
Mark B	4mm
Mark C	3mm

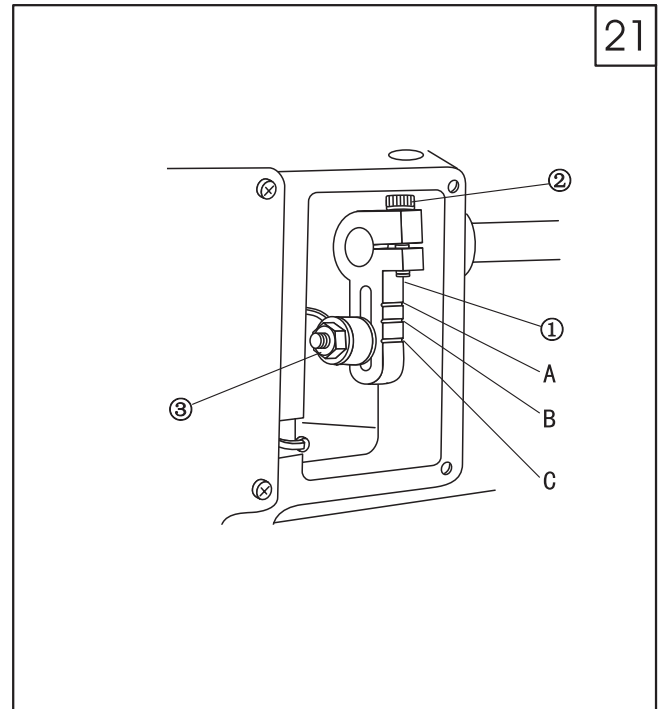

24. Adjusting the cutter (Fig.22)

Adjust the position of fixed knife

Loosen the screw ①, the correct position is: the clearance between the front point of fixed knife and needle plate should be $1.5 \pm 0.2\text{mm}$ and the point should reach the project part of hook saddle, tighten the screw ①. Please use attached fixed knife gauge ③ to adjust the clearance.

Adjust the pressure of movable knife

Loosen the screw ②, turn the handwheel, when the clearance of front point between movable knife and fixed knife is 6-7mm, the pressure of movable knife is standard.

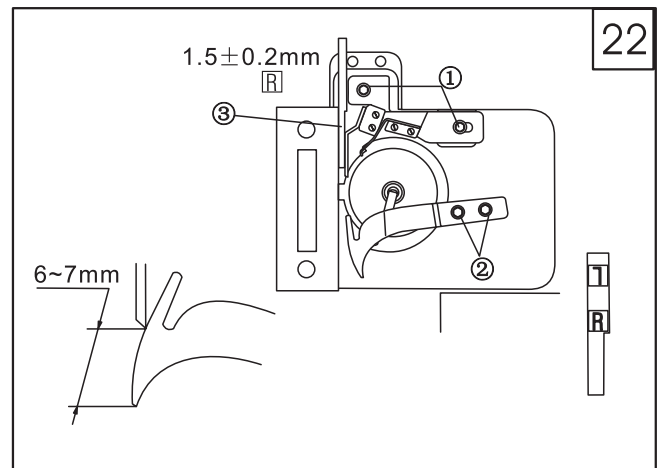

25. Stop position (Fig.23)

1. Align the mark ① on the casting with the mark ② on the handwheel, the meaning of every stop position, please refer to below table.

2. To adjust the needle up position by screw ③, to adjust the needle down position by screw ④.

Mark on the handwheel	
White-white	Needle up
Yellow	Needle down
Red	For adjusting the cutting driven cam
No color	For lifting needle by reverse turn

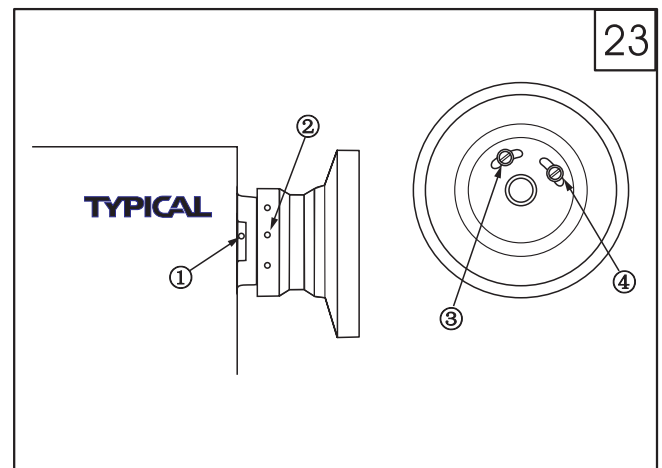

26. Settings for different speeds

Alternating lift amount	Stitch length < 6mm	6mm < Stitch length < 9mm
Less than 2.5mm	2,500rpm	1,800rpm
2.5~4mm	2,200rpm	1,800rpm
4~4.75mm	1,800rpm	1,800rpm
4.75~6.5mm	1,600rpm	1,600rpm

Make proper settings for different speeds accordingly. Do not surpass the standard.

27. Troubleshooting

Trouble	Possible cause	Solution
1. Thread breaking (2~3mm thread left on the cloth)	<ol style="list-style-type: none"> 1. Damage on the rotating hook slots, needle point, hook tip and needle plate 2. Needle thread too tight 3. Collision between needle and rotating hook 4. Rotating hook oiled insufficiently 5. Needle thread too loose 6. Thread take-up spring too rigid 7. Too fast or slow timing of rotating hook and needle 	<ol style="list-style-type: none"> 1. Polish the damaged position, thorns with sand paper or rasp 2. Weaken the needle thread tension 3. Refer to 22. Timing between needle and rotating hook 4. Adjust oil amount (7. Lubrication) 5. Increase the needle thread tension 6. Reduce the rigidity of take-up spring 7. Refer to 22. Timing between needle and rotating hook
2. Skipped stitch	<ol style="list-style-type: none"> 1. Too fast or slow timing of rotating hook and needle 2. Presser foot pressure too weak 3. Clearance between the top of needle hole and the rotating hook tip not proper 4. Wrong needle 	<ol style="list-style-type: none"> 1. Refer to 22. Timing between needle and rotating hook 2. Tighten the pressure adjusting bolt 3. Refer to 22. Timing between needle and rotating hook 4. Replace the needle with correct one
3. Loose stitch	<ol style="list-style-type: none"> 1. Bobbin thread doesn't pass under the tension spring of the bobbin case 2. Roughness on the rotating hook 3. Bobbin stop rotating 4. Bobbin thread too loose 5. Bobbin thread too tight 6. Damage of the needle point 	<ol style="list-style-type: none"> 1. Refer to 10. Threading the bobbin 2. Polish with sand paper or rasp 3. Replace bobbin or rotating hook 4. Increase the bobbin thread tension 5. Reduce the bobbin thread tension 6. Replace the needle

Parts Manual

1. Casting mechanism

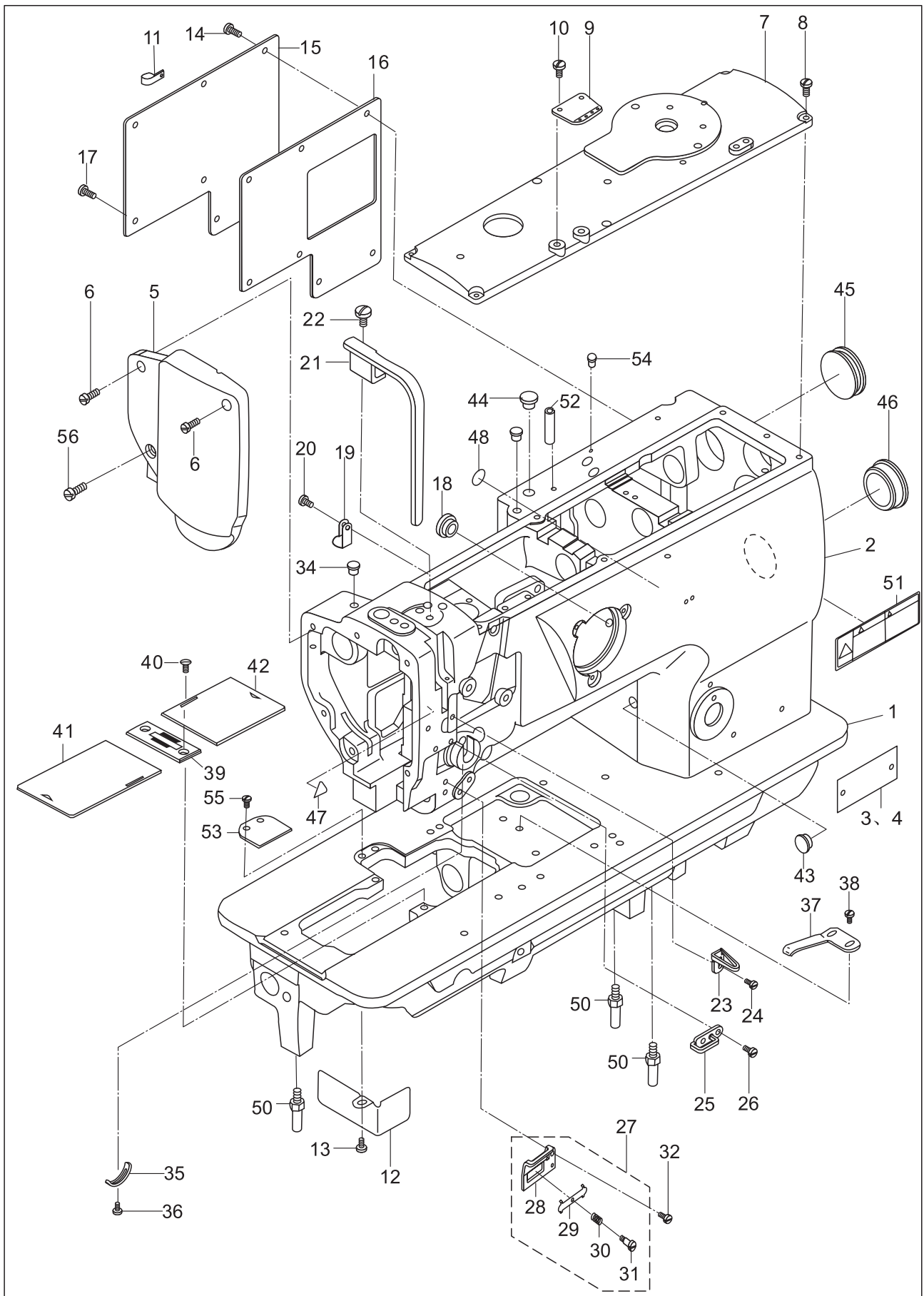

1. Casting mechanism

No.	Part Number	Name	Qt.	Remark
1	199WF2-001	Bed	1	
2	199WF2-016	Arm	1	
3	229WF2-001A	Model plate	1	
4	229WF2-001B	Model plate	1	
5	92WF2-003	Face plate assy	1	
6	1WF5-039	Screw	2	
7	92WF2-009	Top cover	1	
8	21WF4-047	Screw	6	SM11/64" × 40
9	199WF2-017	Upper thread guide	1	
10	21WF1-062	Screw	1	SM3/16" × 32
11	84WF1-022	Wire clamp	3	
12	199WF2-003	Side cover	1	
13	21WF4-047	Screw	1	SM11/64" × 40
14	1WF5-039	Screw	3	SM11/64" × 40
15	119WF2-003	Back cover	1	
16	119WF2-004	Seal	1	
17	1WF1-011	Screw	4	SM11/64" × 40
18	92WF2-030	Rubber plug	2	
19	84WF1-021	Wire clamp	2	
20	1WF1-011	Screw	2	SM11/64" × 40
21	92WF2-004	Thread take-up lever cover	1	
22	13WF2-045	Screw	1	SM15/64" × 28
23	92WF2-013	Thread guide	1	
24	36WF1-016	Screw	1	SM9/64" × 40
25	92WF2-014	Thread guide	1	
26	1WF1-007	Screw	2	SM9/64" × 40
27	92WF2-015	Lower thread guide assy.	1	
28	92WF2-015A	Thread guide	1	
29	92WF2-015B	Plate	1	
30	92WF2-015C	Spring	1	
31	92WF2-015D	Screw	1	SM9/64" × 40
32	1WF1-007	Screw	1	SM9/64" × 40
34	92WF2-029	Rubber plug	2	
35	50WF2-022	Plate for take-up spring	1	
36	1WF1-026	Screw	1	SM9/64" × 40
37	199WF2-004	Leaf spring	1	
38	2KT5-005	Screw	2	SM11/64" × 40

1. Casting mechanism

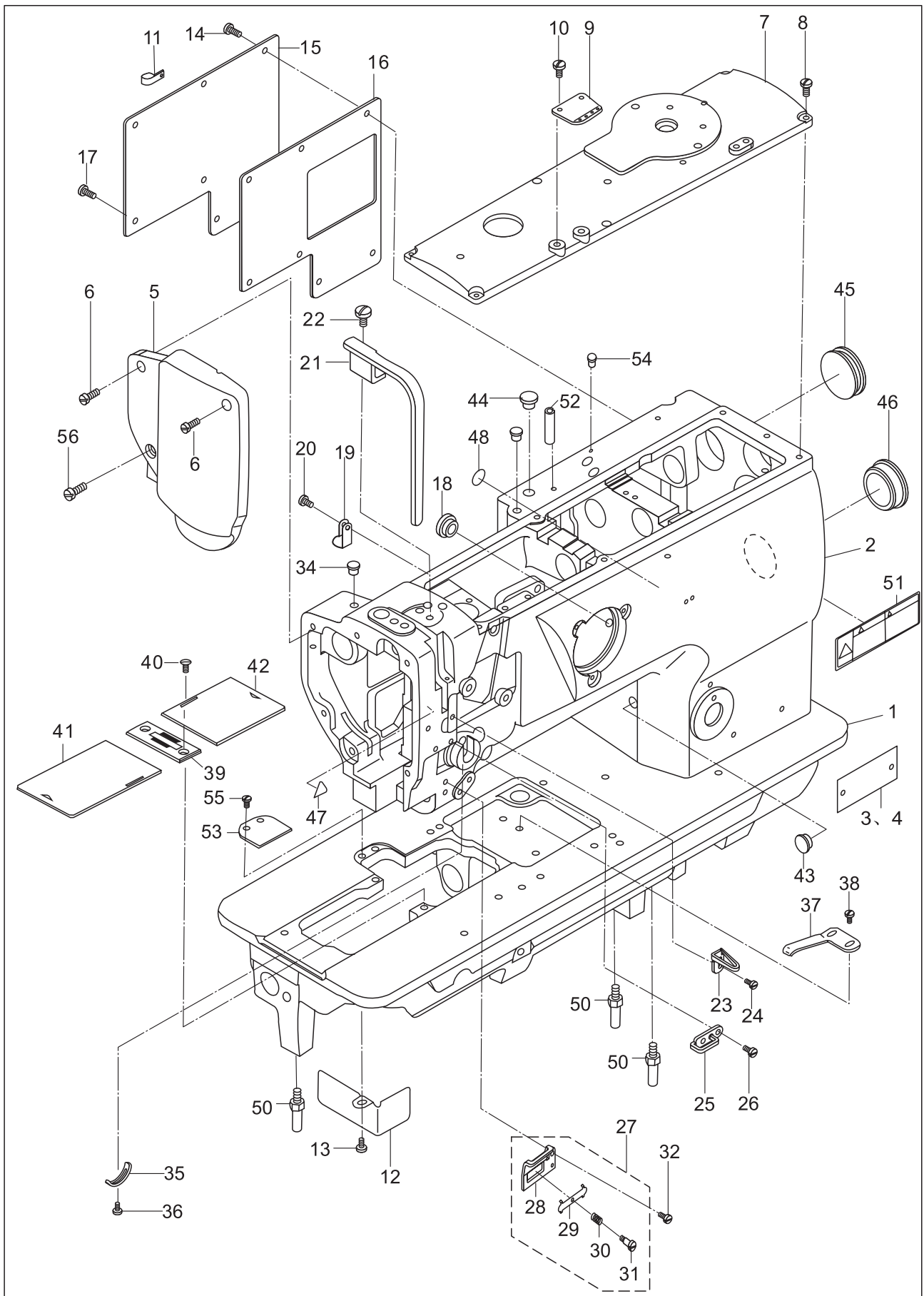

1. Casting mechanism

No.	Part Number	Name	Qt.	Remark
39	199WF2-005	Needle plate	1	
40	199WF2-006	Screw	2	
41	199WF2-007	Sliding plate (L)	1	
42	199WF2-008	Sliding plate (R)	1	
43	92WF2-028	Rubber plug	1	
44	92WF2-028	Rubber plug	1	
45	92WF2-032	Rubber plug	1	
46	92WF2-031	Rubber plug	1	
47	59WF1-010	Caution mark	1	
48	21WF4-050	Ground wire mark	1	
50	199WF2-010	Screw	3	
51	1KT1-005	Caution label	1	
52		Pin	1	GB/T 879.1 4.5 × 20
53	228WF2-002	Auxiliary cover	1	
54	199WF2-015	Rubber plug	2	
55	199WF2-014	Screw	2	SM9/64" × 40
56	26210	Screw	1	SM15/64" × 28

2. Arm shaft & thread take-up mechanism

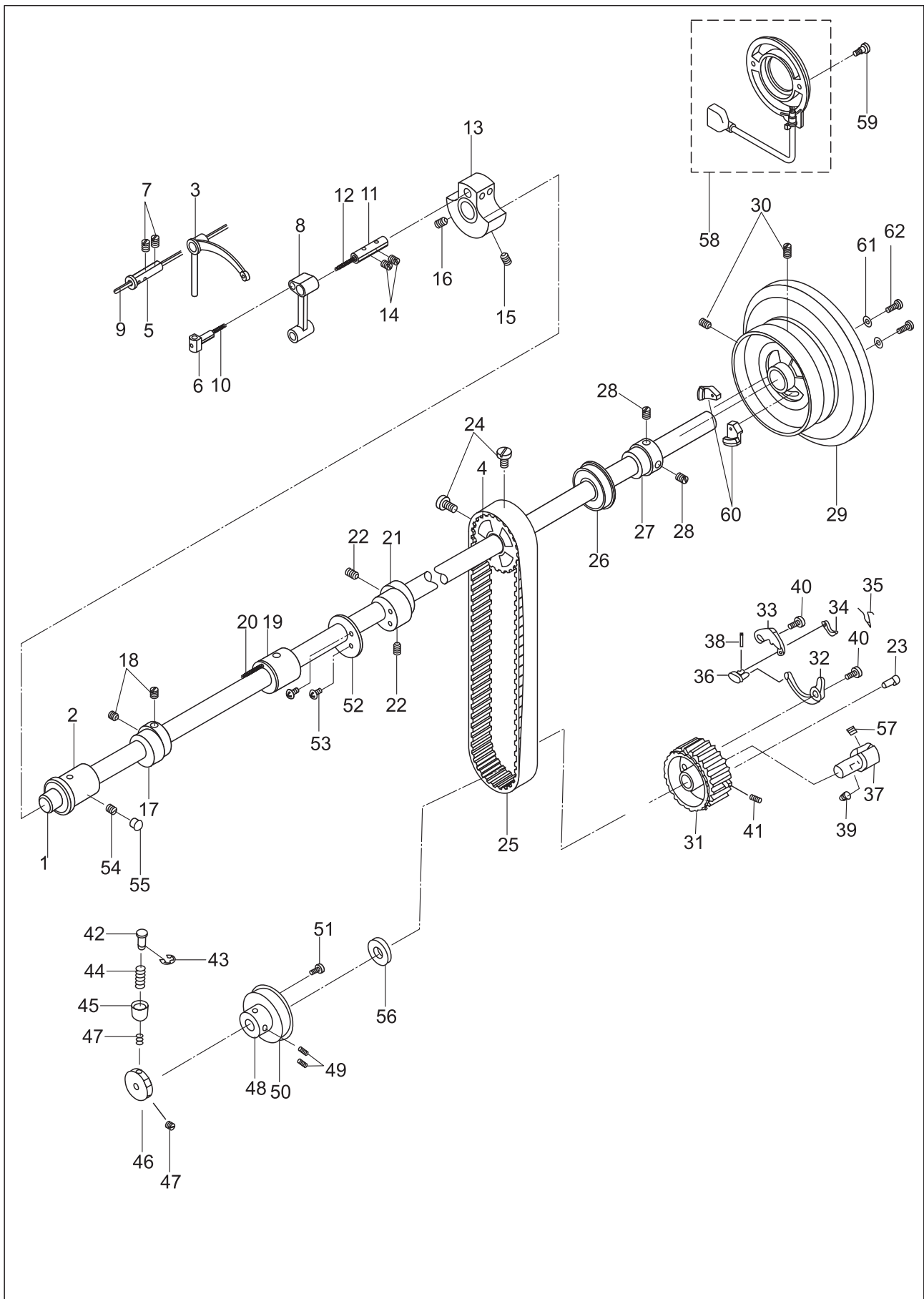

2. Arm shaft & thread take-up mechanism

No.	Part Number	Name	Qt.	Remark
1	199WF1-051	Arm shaft	1	
2	92WF1-009	Front bushing, arm shaft	1	
3	199WF1-001	Thread take-up lever	1	
4	199WF1-002	Synchronized pulley assy. U	1	
5	16WF1-010	Pin shaft	1	
6	50WF1-006	Slide block	1	
7	1WF50-019	Screw	2	SM15/64" × 28
8	92WF1-006	Needle bar link	1	
9	199WF1-003	Oil wick	1	Φ2.5 × 450
10	199WF1-004	Oil wick	1	L=30
11	50WF1-008	Pin	1	
12	199WF1-005	Oil wick	1	Φ7 × 30
13	92WF1-007	Needle bar crank	1	
14	1WF5-019	Screw	2	SM15/64" × 28
15	50WF1-013	Screw	1	SM9/32" × 28
16	20T2-007	Screw	1	SM9/32" × 28
17	92WF3-014	Feed cam	1	
18	1WF2-010	Screw	2	SM1/4" × 40
19	92WF1-010	Middle bushing, arm shaft	1	
20	199WF1-006	Oil wick	1	Φ2 × 150
21	92WF3-029	Feed eccentric cam	1	
22	1WF2-010	Screw	2	SM1/4" × 40
23	22WF1-015	Pin	1	
24	92WF1-014	Screw	2	
25	92WF1-034	Teeth belt	1	
26	36WF3-019A	Bearing, arm shaft	1	50105 25 × 47 × 12
27	92WF1-011	Bushing	1	
28	57WF-009	Screw	2	M6
29	228WF1-010	Hand wheel	1	
30	1WF5-019	Screw	2	
31	110WF1-017	Synchronized pulley assy. L	1	
32	22WF1-013	Clutch plate	1	
33	22WF1-018	Stop plate	1	
34	22WF1-016	plate	1	
35	22WF1-014	Twist spring	1	
36	22WF1-017	Link	1	
37	103614	Bushing	1	
38	B225001	Pin	1	GB91-86 1.2 × 8

2. Arm shaft & thread take-up mechanism

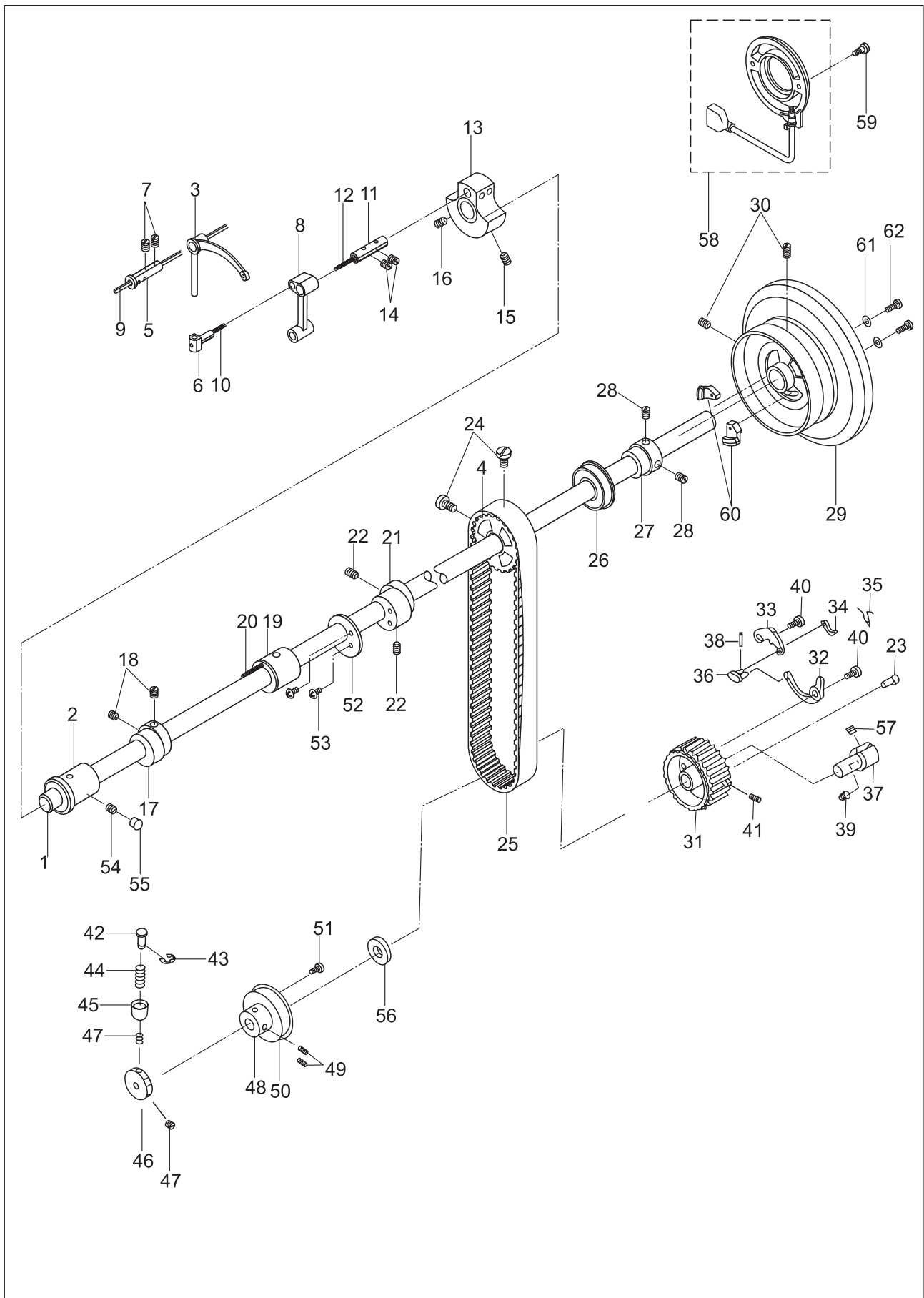

2. Arm shaft & thread take-up mechanism

No.	Part Number	Name	Qt.	Remark
39	22WF1-052	Screw	1	SM1/4" × 40
40	22WF1-019	Screw	2	
41	22WF1-020	Screw	2	
42	199WF1-020	Push button	1	
43		Retaining ring	1	GB896 5
44	199WF1-021	Spring	1	
45	199WF1-022	Bushing	1	
46	199WF1-023	Wheel	1	
47	18227	Screw	1	SM15/64" × 28
48	199WF1-024	Collar	2	
49	21WF1-022	Screw	1	SM1/4" × 40
50		Ball bearing	2	50104 20 × 42 × 12
51	199WF1-025	Screw	1	
52	92WF3-030	Retaining block	2	
53	7WF5-017	Screw	1	SM11/64" × 40
54	1WF5-019	Screw	2	SM15/64" × 28
55	92WF2-029	Rubber plug	1	
56	199WF1-026	Washer	2	
57	22WF1-052	Screw	1	
58	119WF10-001	Synchronizer	1	
59	119WF10-002	Screw	2	
60	119WF10-003	Synchronizer magnet assy.	2	
61	2KT7-009	Washer	2	
62	52WF5-003	Screw	2	

3. Needle bar rocking frame mechanism

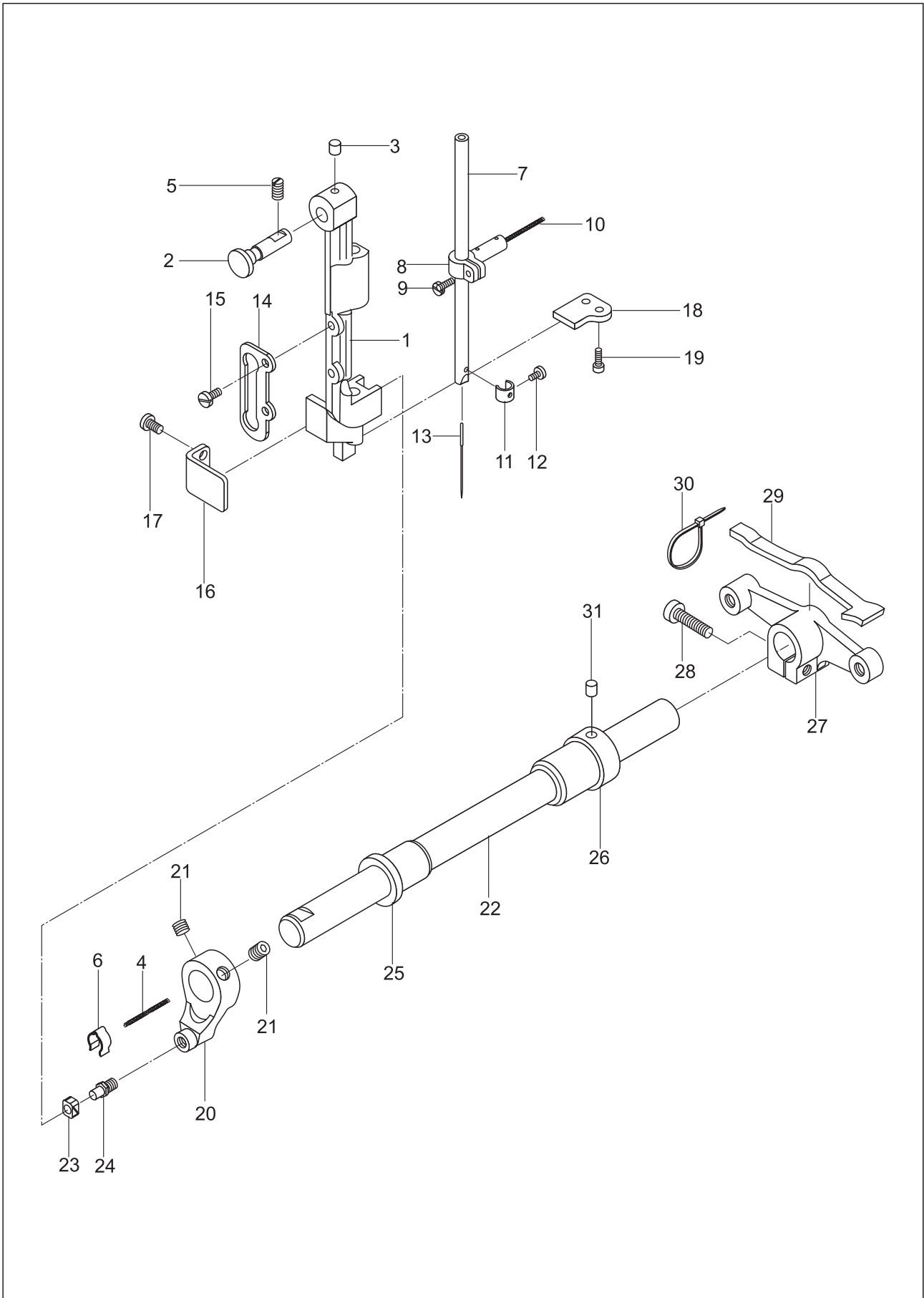

3. Needle bar rocking frame mechanism

No.	Part Number	Name	Qt.	Remark
1	92WF3-008	Needle bar rocking frame	1	
2	92WF3-009	Pin	1	
3	92WF3-007	Oil felt	1	
4	199WF3-001	Oil wick	1	Φ2 × 160
5	42WF3-007	Screw	1	
6	92WF3-003	Leaf spring	1	
7	50WF1-001	Needle bar	1	
8	50WF3-003	Needle bar joint	1	
9	36WF3-029B	Screw	1	
10	199WF3-002	Oil wick	1	Φ6 × 20
11	92WF1-003	Needle bar thread guide	1	
12	22T2-017	Screw	1	SM1/8" × 44
13		Needle	1	DP × 17 23#
14	50WF3-030	Guide rail	1	
15	1WF1-011	Screw	2	SM11/64" × 40
16	92WF3-011	Position plate (2)	1	
17	W01111	Screw	2	SM11/64" × 40
18	92WF3-010	Position plate (1)	1	
19	21WF1-054	Screw	2	SM91/64" × 40
20	92WF3-002A	Crank	1	
21	92WF3-070	Screw	2	
22	92WF3-001	Rocking shaft	1	
23	92WF3-004	Slide block	1	
24	92WF3-002B	Pin	1	
25	92WF3-005	Bushing , L	1	
26	92WF3-006	Bushing, R	1	
27	92WF3-012	Crank	1	
28	52WF1-050	Screw	1	
29	92WF3-013	Oil felt	1	
30	2KT-001A	Band	1	
31	92WF3-007	Oil felt	1	

4. Upper feed mechanism

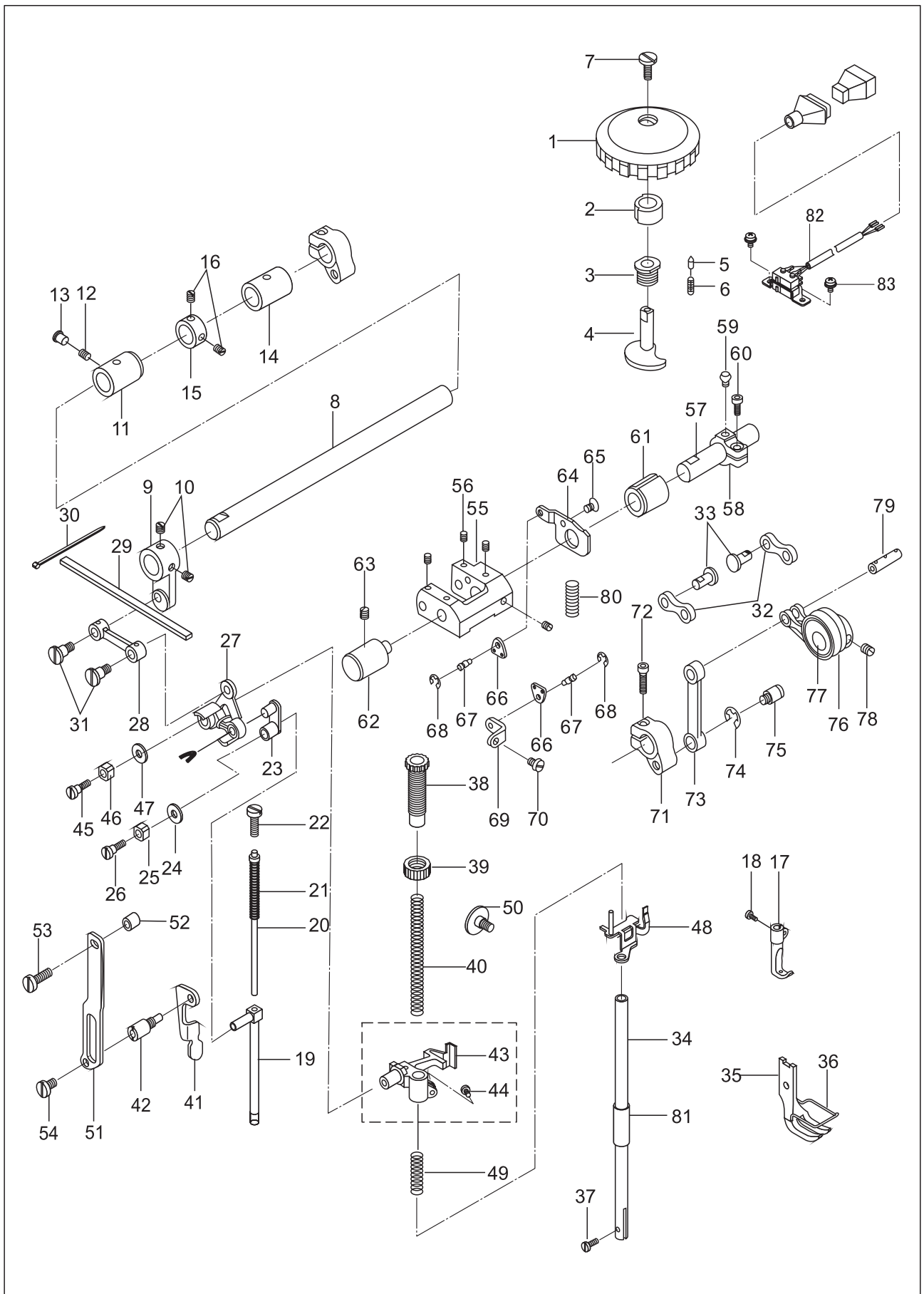

4. Upper feed mechanism

No.	Part Number	Name	Qt.	Remark
1	119WF7-017A	Dial	1	
2	119WF7-017B	Bushing	1	
3	119WF7-019	Bushing	1	
4	119WF7-018	Shaft	1	
5	994131	Pin	1	
6	93WF8-002	Spring	1	
7	302395	Screw	1	
8	92WF3-018	Shaft	1	
9	92WF3-019	Crank	1	
10	2KT5-027	Screw	2	SM1/4" × 40
11	199WF4-001	Front bushing	1	
12	1WF5-019	Screw	1	SM15/64" × 28
13	92WF2-029	Rubber plug	1	
14	92WF3-021	Rear bushing	1	
15	92WF3-022	Collar	1	
16	22T3-002B2	Screw	2	SM1/4" × 40
17	92WF3-023	Walking foot	1	
18	50WF3-020	Screw	1	
19	50WF3-018	Walking foot lifting bar	1	
20	92WF3-024	Spring guide bar assy	1	
21	50WF3-032	Spring	1	
22	6K1-048	Regulating screw	1	SM15/64" × 28
23	50WF3-027	Link	1	
24	50WF3-028	Felt	1	
25	50WF3-029	Slide block	1	
26	20T4-006	Screw	1	SM11/64" × 40
27	92WF3-025	Lifting plate	1	
28	92WF3-026	Link	1	
29	92WF3-027	Oil felt	1	
30	2KT7-001A	Band	2	
31	92WF3-028	Screw	2	
32	119WF7-011	Link	2	
33	994118	Pin shaft	2	
34	22WF3-005	Presser bar	1	
35	92WF4-001	Presser foot	1	
36	92WF4-002	Finger guard	1	
37	22WF3-014	Screw	1	SM9/64" × 40
38	92WF4-003	Regulating bolt	1	SM1/2" × 28
39	1KT4-002	Nut	1	SM1/2" × 28
40	92WF4-023	Spring	1	
41	92WF4-004	Foot lift lever	1	
42	92WF4-005	Lift lever shaft	1	

4. Upper feed mechanism

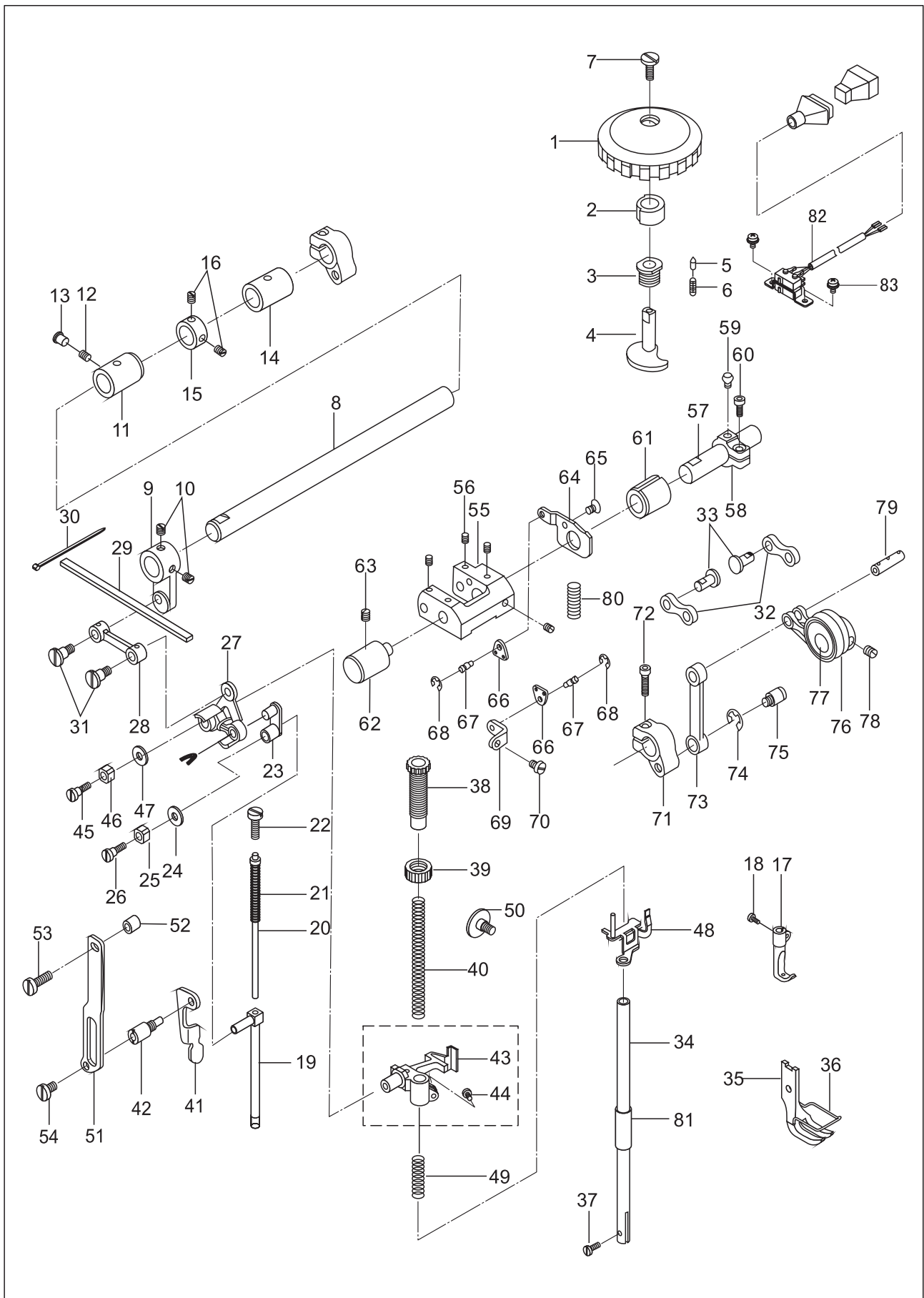

4. Upper feed mechanism

No.	Part Number	Name	Qt.	Remark
43	92WF4-006	Bracket	1	
44	1WF1-011	Screw	1	SM11/64" × 40
45	92WF4-007	Screw	1	
46	50WF3-029	Slide block	1	
47	92WF4-008	Washer	1	
48	92WF4-009	Releasing plate	1	
49	50WF4-013	Spring	1	
50	50WF4-014	Screw	1	
51	92WF4-010	Guide plate	1	
52	92WF4-011	Washer	1	
53	60WF4-003	Screw(U)	1	SM15/64" × 28
54	52WF3-027	Screw(L)	1	SM15/64" × 28
55	119WF7-001	Adjusting bracket	1	
56	6K2-043	Screw	4	
57	119WF7-003	Shaft	1	
58	119WF7-004	Crank	1	
59	119WF7-005	Screw	1	
60	72WF5-021	Screw	1	
61	119WF7-002	Bushing	1	
62	92WF3-037	Shaft	1	
63	1WF5-019	Screw	1	SM15/64" × 28
64	119WF7-012	Retaining plate	1	
65		Screw	1	GB/T819.2 M5 × 8
66	119WF7-014	Connecting plate	2	
67	119WF7-015	Screw	2	
68		Retaining ring	2	GB896 5
69	119WF7-016	Hanger	1	
70	50WF3-089	Screw	1	
71	119WF7-009	Crank	1	
72	80WF6-025	Screw	1	
73	119WF7-008B	Link	1	
74		Retaining ring	1	GB896 8
75	119WF7-010	Screw	1	
76	119WF7-008A	Link	1	
77	119WF7-007	Needle bearing	1	
78	21WF1-022	Screw	1	
79	119WF7-008C	Pin shaft	1	
80	119WF7-013	Spring	1	
81	50WF4-001	Bushing	1	
82	119WF7-020	Speed adjusting assy.	1	
83		Screw	2	GB/T65 M4x8

5. Lower feed, reverse and feed regulating

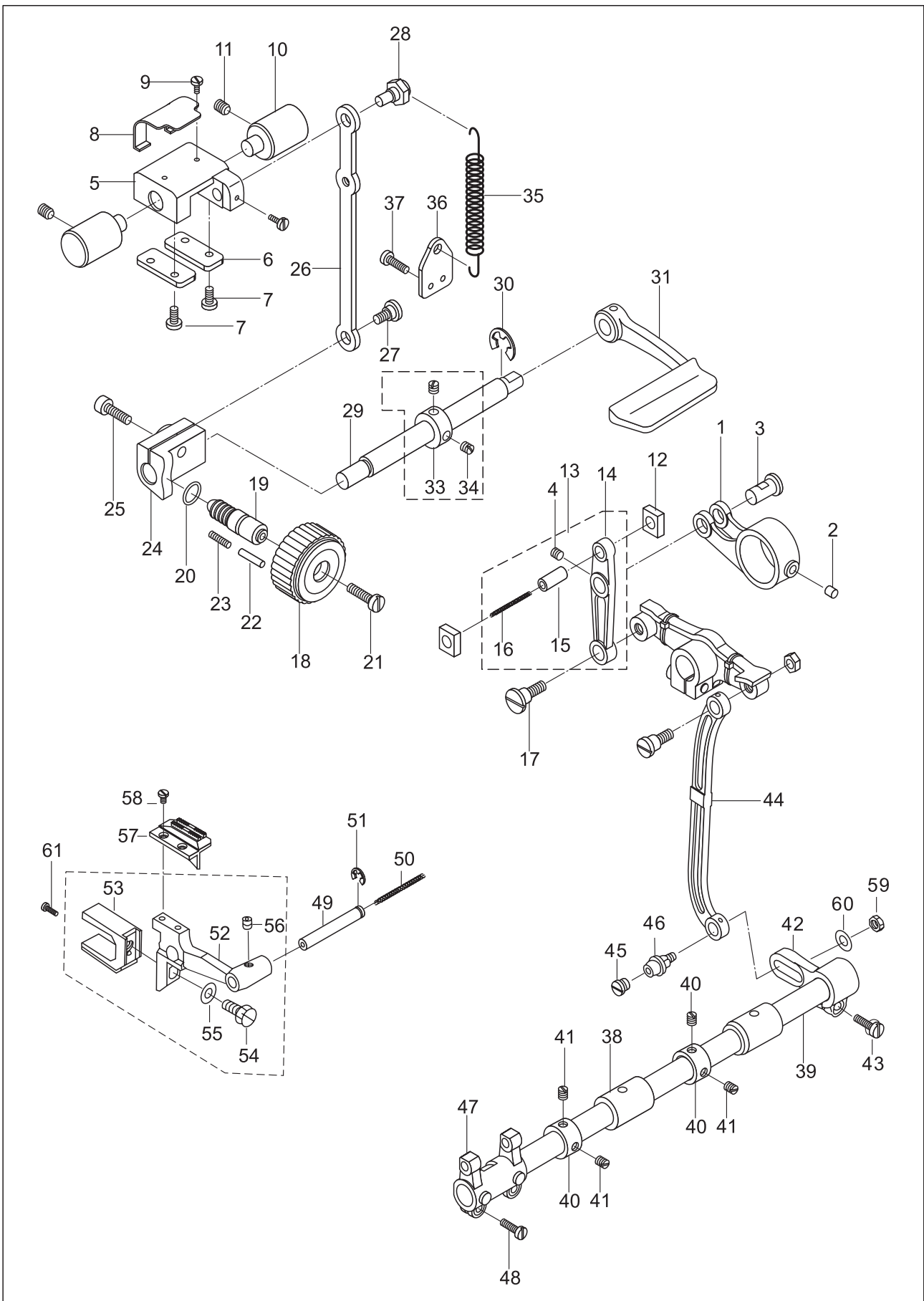

5. Lower feed, reverse and feed regulating

No.	Part Number	Name	Qt.	Remark
1	92WF3-031	Feed link	1	
2	92WF3-032	Oil felt	1	
3	92WF-033	Pin	1	
4	6K2-043	Screw	1	M5
5	92WF3-034	Reverse feed bracket	1	
6	92WF3-035	Retaining plate	2	
7	1WF1-011	Screw	4	
8	92WF3-036	Presser plate	1	
9	16WF1-059	Screw	2	SM9/64" × 40
10	92WF3-037	Shaft	2	
11	1WF5-019	Screw	2	SM15/64" × 28
12	92WF3-038	Slide block	2	
13	92WF3-039	Feed rocking bar assy.	1	
14	92WF3-039A	Feed rocking bar	1	
15	92WF3-039B	Pin	1	
16	199WF3-003	Oil wick	1	Φ1.5 × 35
17	92WF3-040	Screw	1	
18	92WF3-041	Stitch regulating dial	1	
19	92WF3-042	Screw bar	1	
20	92WF3-043	Seal ring	1	
21	92WF3-044	Screw	1	SM3/16" × 28
22	17WF4-035	Stop pin	1	
23	50WF3-058	Spring	1	
24	92WF3-045	Holder	1	
25	6K2-024	Screw	1	M6
26	92WF3-046	Link	1	
27	92WF3-047	Screw	1	
28	92WF3-048	Eccentric pin	1	
29	92WF3-049	Reverse feed lever shaft	1	
30	92WF3-071	Retaining ring	1	GB896 9
31	92WF3-050	Reverse feed lever	1	
33	92WF3-052	Collar	1	
34	22T3-002B2	Screw	2	SM1/4" × 40
35	92WF3-053	Spring	1	
36	92WF3-054	Spring hook	1	
37	1WF3-009	Screw	2	SM11/64" × 40
38	92WF3-021	Feed shaft bushing	2	

5. Lower feed, reverse and feed regulating

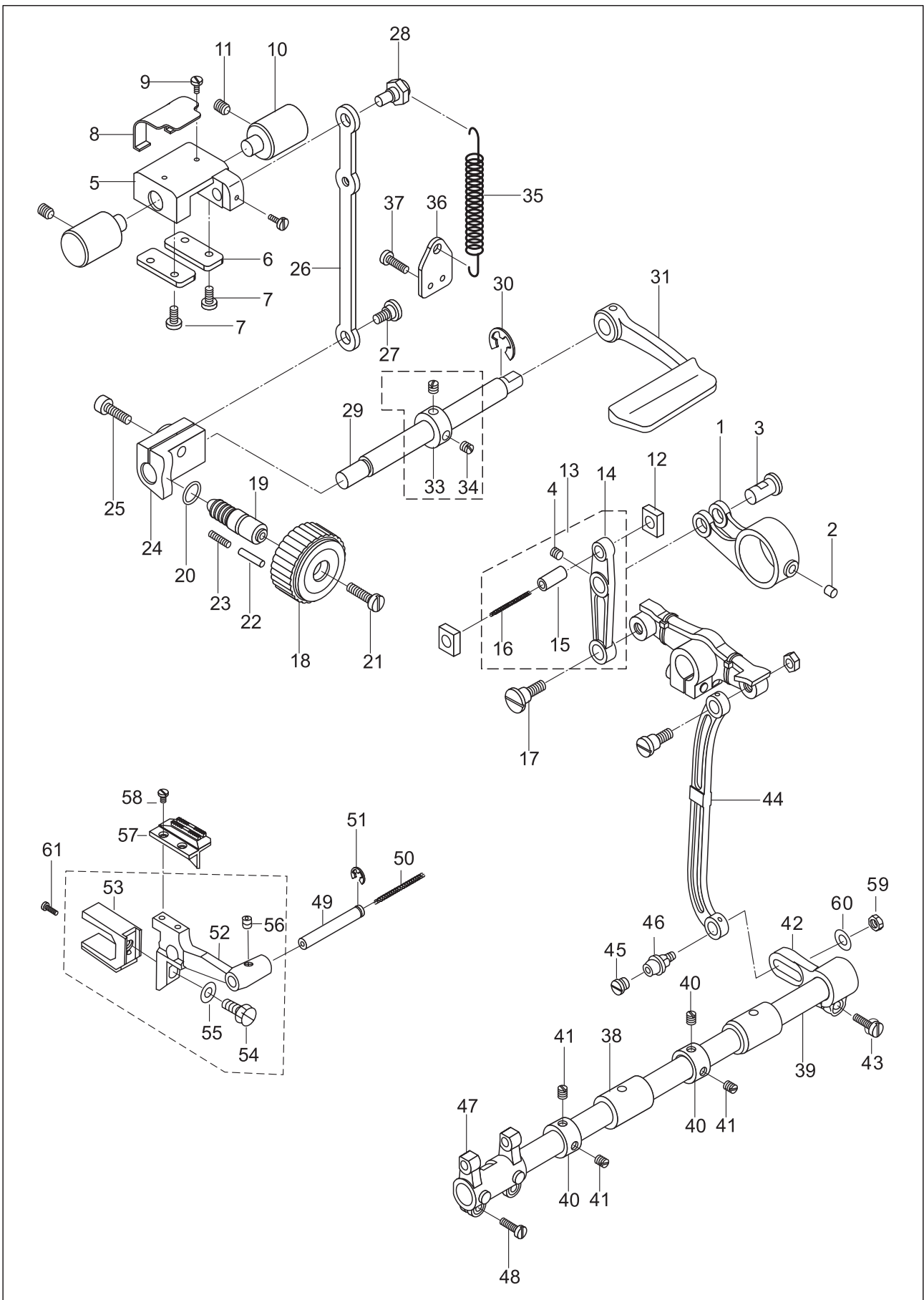

5. Lower feed, reverse and feed regulating

No.	Part Number	Name	Qt.	Remark
39	92WF3-055	Feed shaft	1	
40	92WF3-022	Feed shaft collar	2	
41	22T3-002B2	Screw	4	SM1/4" × 40
42	119WF3-001	Driving crank	1	
43	41WF3-018	Screw	1	SM3/16" × 28
44	92WF3-058	Link	1	
45	119WF3-003	Screw	1	
46	119WF3-002	Screw	1	
47	92WF3-060	Feed crank	1	
48	1WF3-009	Screw	2	SM11/64" × 40
49	92WF3-061	Pin	1	
50	199WF3-004	Oil wick	1	Φ2.5 × 120
51	92WF3-072	Retaining ring	1	GB896 5
52	199WF3-005	Feed dog support	1	
53	199WF3-006	Lifting fork	1	
54	42WF1-008	Screw	1	SM15/64" × 28
55	42WF1-009	Washer	1	
56	80WF6-036	Screw	1	
57	199WF3-007	Feed dog	1	
58	199WF3-008	Screw	2	
59	22WF3-004	Nut	1	
60	71WF3-058	Washer	1	
61	13WF6-008	Screw	1	

6. Lower shaft and rotating hook

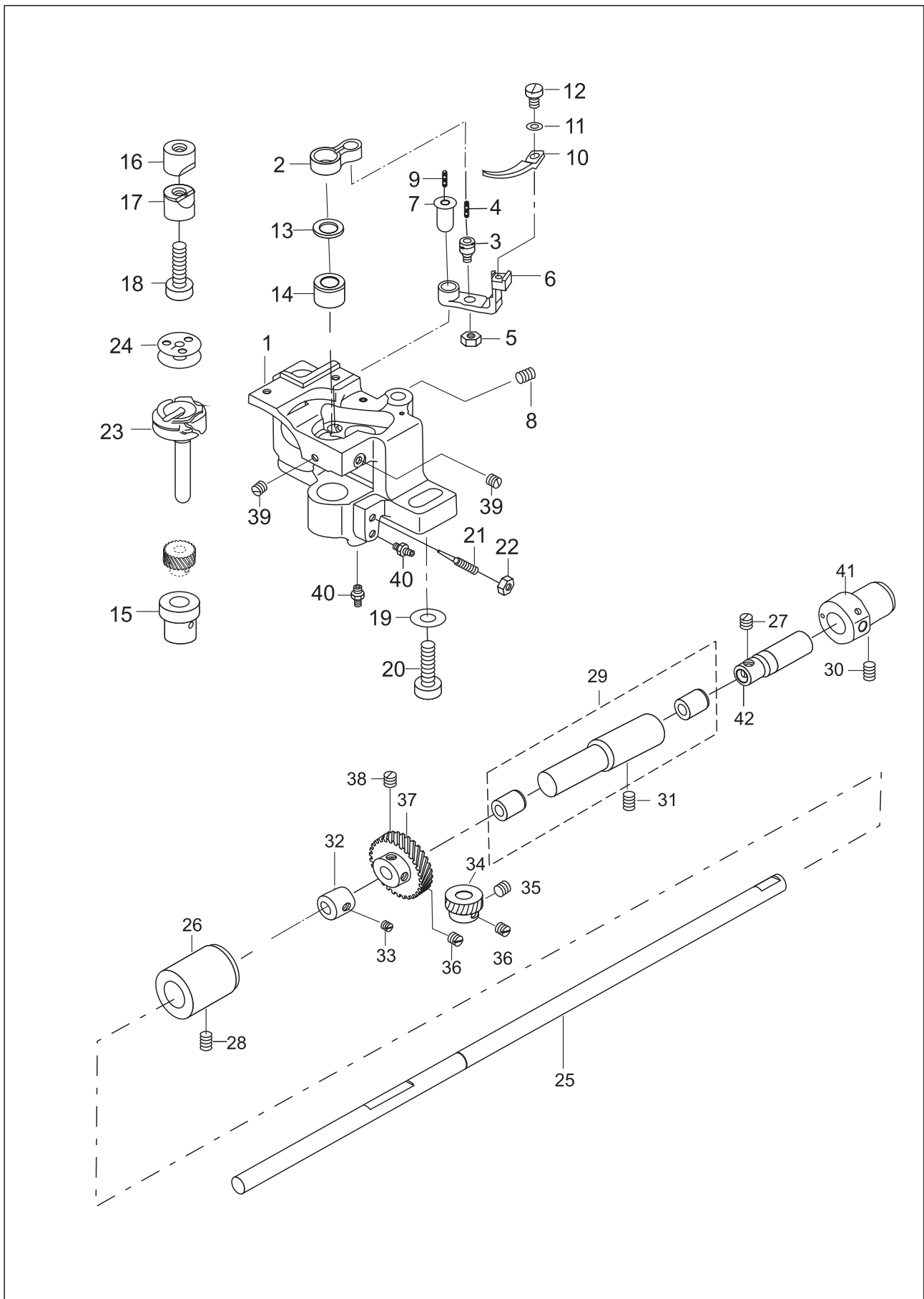

6. Lower shaft and rotating hook

No.	Part Number	Name	Qt.	Remark
1	228WF1-002	Rotating hook saddle	1	
2	199WF1-028	Thread opener link	1	
3	199WF1-032	Pin	1	
4	199WF1-030	Oil wick	1	Φ3×15
5	27WF4-008	Nut	1	
6	228WF1-003	Thread opener supporter	1	
7	228WF1-004	Shaft	1	
8	52WF2-030	Screw	1	SM11/64"×40
9	199WF1-033	Oil wick	1	Φ3×20
10	228WF1-005	Thread opener	1	
11	36WF1-042	Washer	1	
12	21WF2-038	Screw	1	SM9/64"×40
13	228WF1-006	Washer(optional)	1	1.7~1.8
	199WF1-035	Washer(optional)	1	1.1~1.6
14	228WF1-007	Upper bushing, rotating hook	1	
15	199WF1-037	Lower bushing, rotating hook	1	
16	199WF1-038	Block A	1	
17	199WF1-039	Block B	1	
18	1WF2-060	Bolt	1	
19	199WF1-040	Washer	1	GB/T 70.1 M8×40
20		Bolt	1	
21	92WF1-031	Screw	1	
22	27WF4-008	Nut	1	
23	228WF1-008	Rotating hook assy.	1	
24	228WF1-011	Bobbin	1	
25	199WF1-042	Lower shaft	1	
26	199WF1-043	Left bushing, lower shaft	1	
27	1WF2-009	Screw	1	SM1/4"×40
28	17WF4-016	Screw	1	SM15/64"×28
29	199WF1-044	Middle bushing assy., lower shaft	1	
30	17WF4-016	Screw	1	SM15/64"×28
31	17WF4-016	Screw	1	SM15/64"×28
32	199WF1-045	Feed dog lifting cam	1	
33	22WF1-022	Screw	1	SM15/64"×28
34	199WF1-046	Rotating hook shaft gear	1	
35	21WF1-033	Screw	1	SM1/4"×40
36	21WF1-043	Screw	1	SM1/4"×40
37	199WF1-047	Lower shaft gear	1	
38	1WF2-010	Screw	2	SM1/4"×40
39	36WF5-021	Screw	2	SM11/64"×40
40	199WF1-048	Oil tube connector	2	
41	199WF1-049	Bushing	1	
42	199WF1-050	Shaft, oil pump	1	

7. Thread tension components

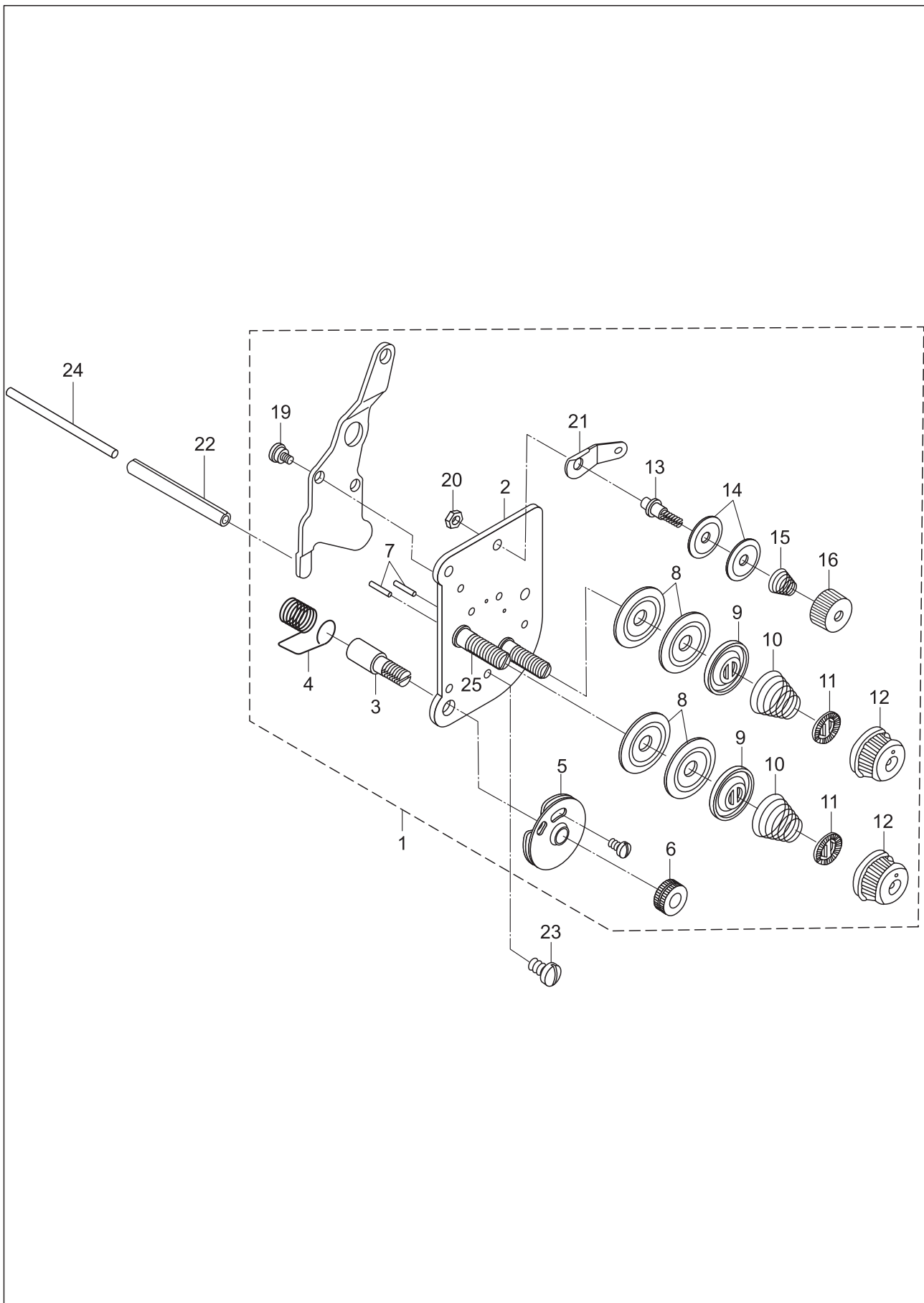

7. Thread tension components

No.	Part Number	Name	Qt.	Remark
1	119WF2-005	Thread tension assy.	1	
2	119WF2-005A	Setting plate	1	
3	92WF2-018C	Thread take-up spring pin	1	
4	92WF2-018B	Thread take-up spring	1	
5	16WF2-046A8	Thread control plate	1	
6	16WF2-046A11	Thumb nut	1	
7	21WF4-024	Tension release pin	1	
8	22T1-012F5	Tension disc	2	
9	22T1-012F4	Tension release disc	2	
10	21WF4-031	Thread tension spring	1	
11	153209	Retainer	1	
12	21WF4-030	Nut	1	
13	92WF2-021A1	Bolt	1	
14	50WF2-035A4	Tension disc	2	
15	50WF2-035A3	Spring	1	
16	50WF2-035A5	Thumb nut	1	
17	119WF2-005B	Plate	1	
18	16WF2-046A9	Screw	1	
19	16WF2-046A15	Screw	2	
20	13WF2-052	Nut	1	
21	50WF2-035A2	Thread guide	1	
22		Pin	1	GB/T 879.1 6×50
23	1WF1-011	Screw	1	SM11/64"×40
24	92WF2-020	Tension release bar	1	
25	21WF4-020	Bolt	1	

8. Bobbin winder & tension components

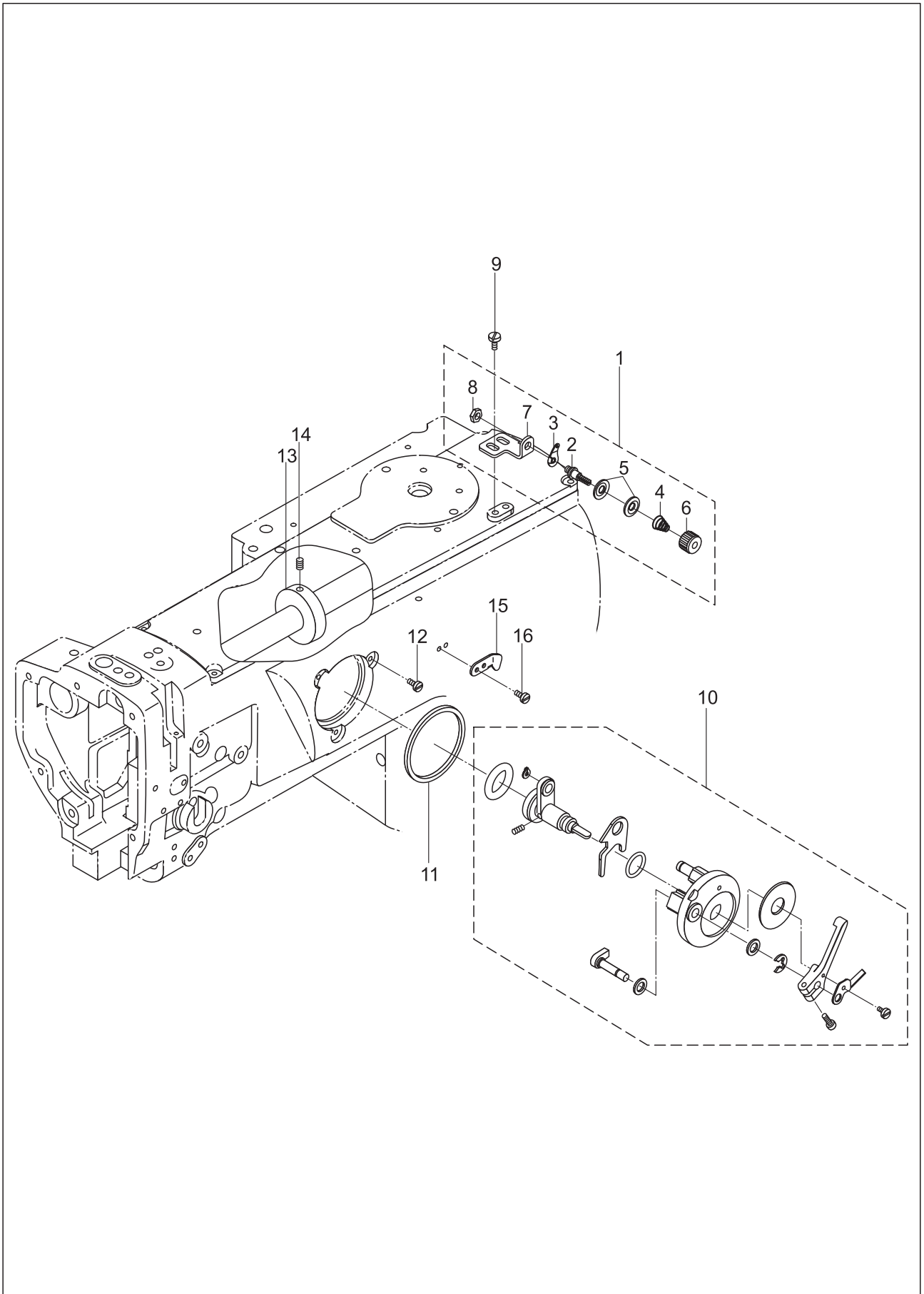

8. Bobbin winder & tension components

No.	Part Number	Name	Qt.	Remark
1	92WF2-021	Bobbin thread tension assy.	1	
2	92WF2-021A	Screw shaft	1	
3	50WF2-035A2	Thread guide	1	
4	50WF2-035A3	Spring	1	
5	50WF2-035A4	Tension disc	2	
6	50WF2-035A5	Thumb nut	1	SM11/64" × 40
7	92WF2-021B	Setting plate	1	
8	2KT5-026	Nut	1	SM11/64" × 40
9	13WF2-040	Screw	2	M4
10	92WF2-025	Thread winder assy.	1	
11	92WF2-026	Seal ring	1	
12	92WF2-027	Screw	3	SM11/64" × 40
13	92WF2-035	Friction wheel	1	
14	6K2-043	Screw	2	
15	92WF2-036	Cutter	1	
16	36WF2-031	Screw	2	

9. Thread trimming mechanism

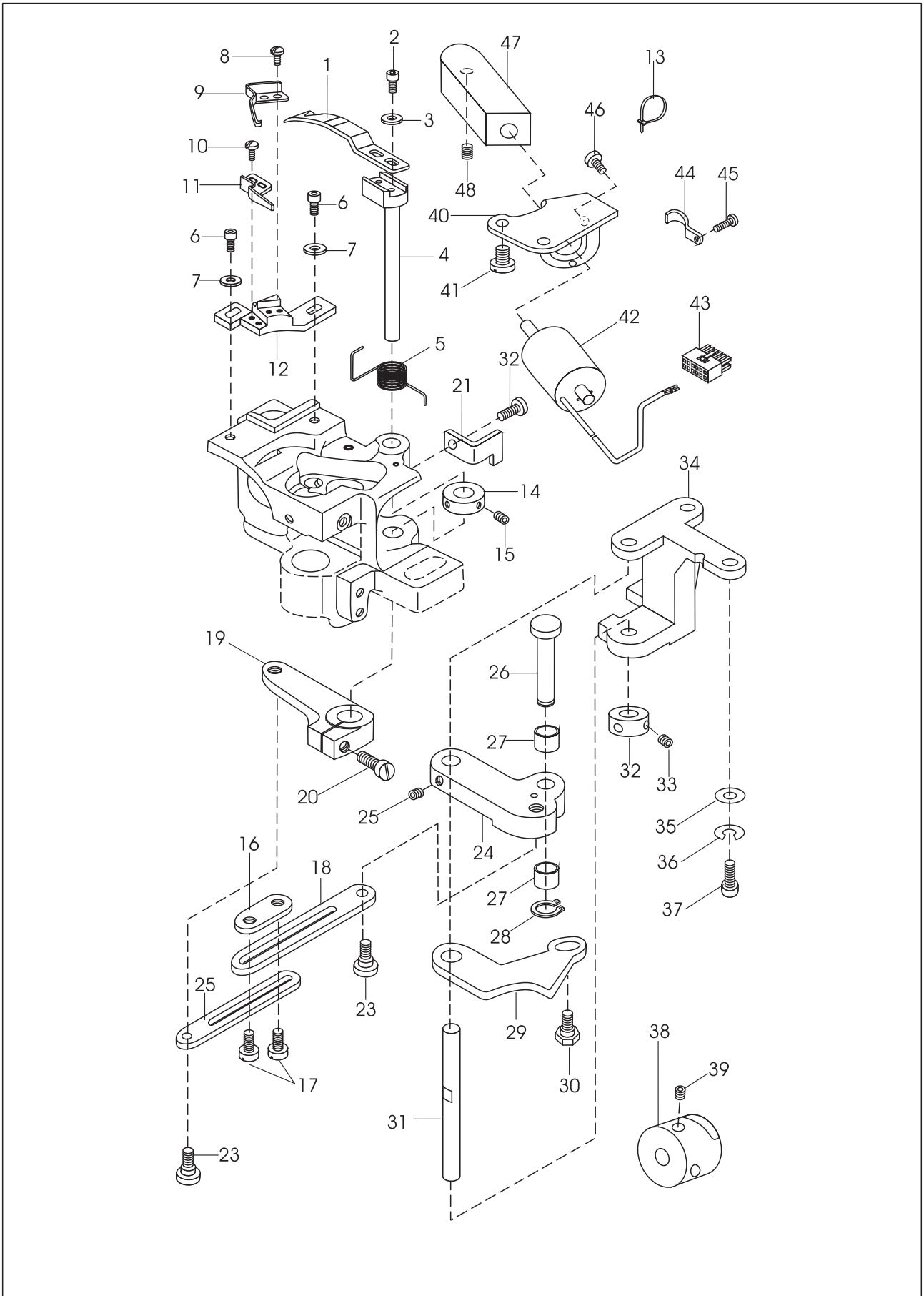

9. Thread trimming mechanism

No.	Part Number	Name	Qt.	Remark
1	228WF4-026	Movable knife	1	
2	228WF4-027	Screw	2	M3 × 8
3		Washer	2	GB/T97.1 3
4	228WF4-025	Movable knife driven shaft	1	
5	228WF4-028	Spring	1	
6	228WF4-035	Screw	2	SM11/64" × 40
7		Washer	2	GB/T95 4
8	13WF2-062	Screw	2	SM3/32" × 56
9	228WF4-032	Spring plate	1	
10	13WF2-062	Screw	2	SM3/32" × 56
11	228WF4-030	Fixed knife	1	
12	228WF4-034	Fixed knife bracket(R)	1	
13	2KT5-001a	Band	1	
14	228WF4-029	Collar	1	
15	36WF5-021	Screw	2	SM11/64" × 40
16	228WF4-016	Lock plate	1	
17	228WF4-017	Screw	2	SM11/64" × 40
18	228WF4-014	Link	2	
19	228WF4-022	Crank	1	
20	41WF3-018	Screw	1	SM3/16" × 28
21	228WF4-024	Stop plate	1	
22	1WF5-042	Screw	1	SM11/64" × 40
23	228WF4-015	Screw	2	
24	228WF4-010	Crank	1	
25	36WF5-025	Screw	2	SM11/64" × 40
26	228WF4-011	Pin shaft	1	
27	228WF4-012	Roller	2	
28		Retaining ring	1	GB896 3.5
29	228WF4-008	Driven link	1	
30	228WF4-009	Screw	1	
31	228WF4-006	Shaft	1	
32	228WF4-007	Collar	1	
33	36WF5-025	Screw	2	SM11/64" × 40
34	228WF4-005	Bracket	1	
35	17WF4-012	Washer	2	
36		Spring washer	2	GB93 6
37	60WF4-003	Screw	2	SM15/64" × 28
38	228WF4-013	Trimming cam	1	
39	2KT5-027	Screw	2	SM1/4" × 40
40	228WF4-001	Solenoid installing bracket	1	
41	13WF2-045	Screw	2	SM15/64" × 28
42	228WF4-002	Trimming solenoid	1	
43	119WF8-018	Connector	1	
44	228WF4-003	Wire clamp	1	

9. Thread trimming mechanism

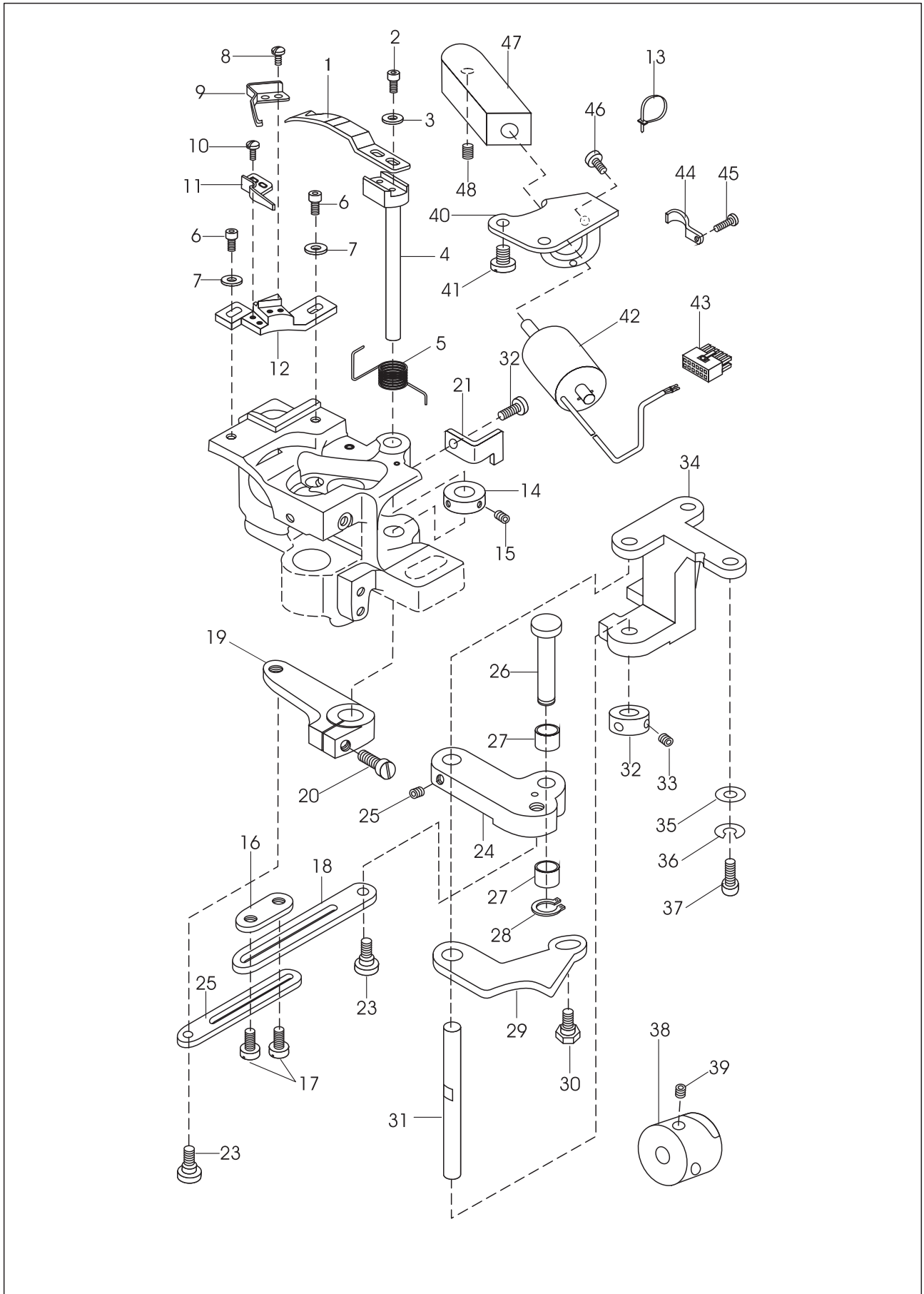

9. Thread trimming mechanism

No.	Part Number	Name	Qt.	Remark
45	52WF2-030	Screw	1	SM11/64" × 40
46	18WF3-021	Screw	2	M4 × 8
47	228WF4-004	Link block	1	
48	21WF1-060	Screw	2	SM11/64" × 40

10.Auto-reverse feed mechanism

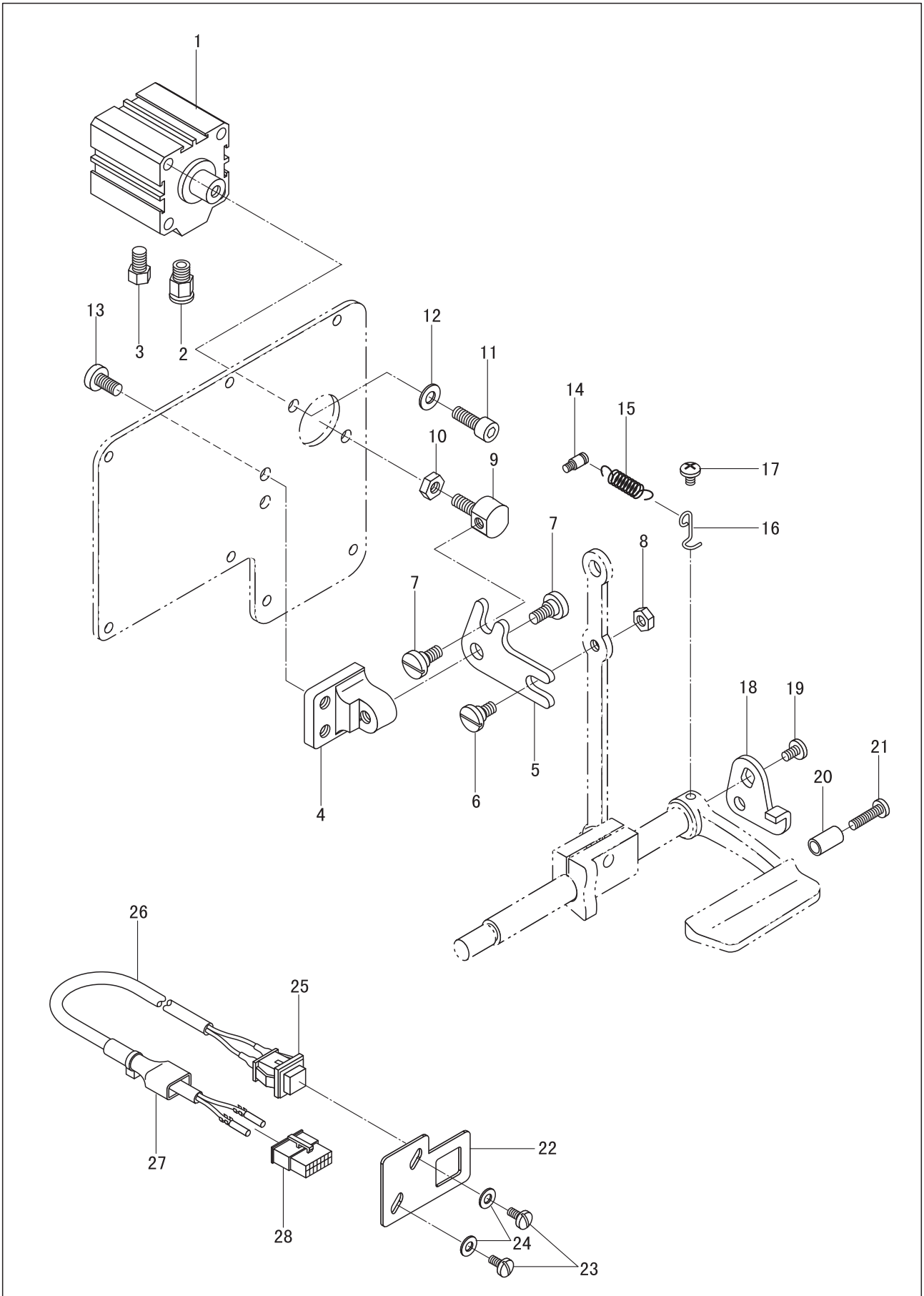

10.Auto-reverse feed mechanism

No.	Part Number	Name	Qt.	Remark
1	119WF8-001A	Cylinder	1	
2	119WF8-001C	Joint	1	
3	119WF8-001B	Silencer	1	
4	119WF8-004	Bracket	1	
5	119WF8-005	Driven lever	1	
6	119WF8-003	Screw	1	
7	119WF8-006	Screw	2	
8	22WF3-004	Nut	1	
9	119WF8-002	Joint	1	
10	22T5-011A7	Nut	1	
11	7KT1-003	Screw	4	
12	72WF2-010	Washer	4	
13	36WF1-056	Screw	2	
14	119WF8-011	Screw bar	1	
15	119WF8-008	Spring	1	
16	119WF8-009	Hook	1	
17	119WF8-010	Screw	1	
18	119WF8-007	Stop plate	1	
19	22T5-010D3	Screw	1	
20	119WF8-012	Block	1	
21	36WF4-027	Screw	1	
22	119WF8-013	Button base	1	
23	22WF4-014	Screw	2	
24	2KT7-009	Washer	2	
25	119WF8-019	Reverse function button	1	
26	119WF8-016	Connector assy.	1	
27	129WF6-014	Plug cover	1	
28	119WF8-018	Plug	1	

11. Tension release mechanism

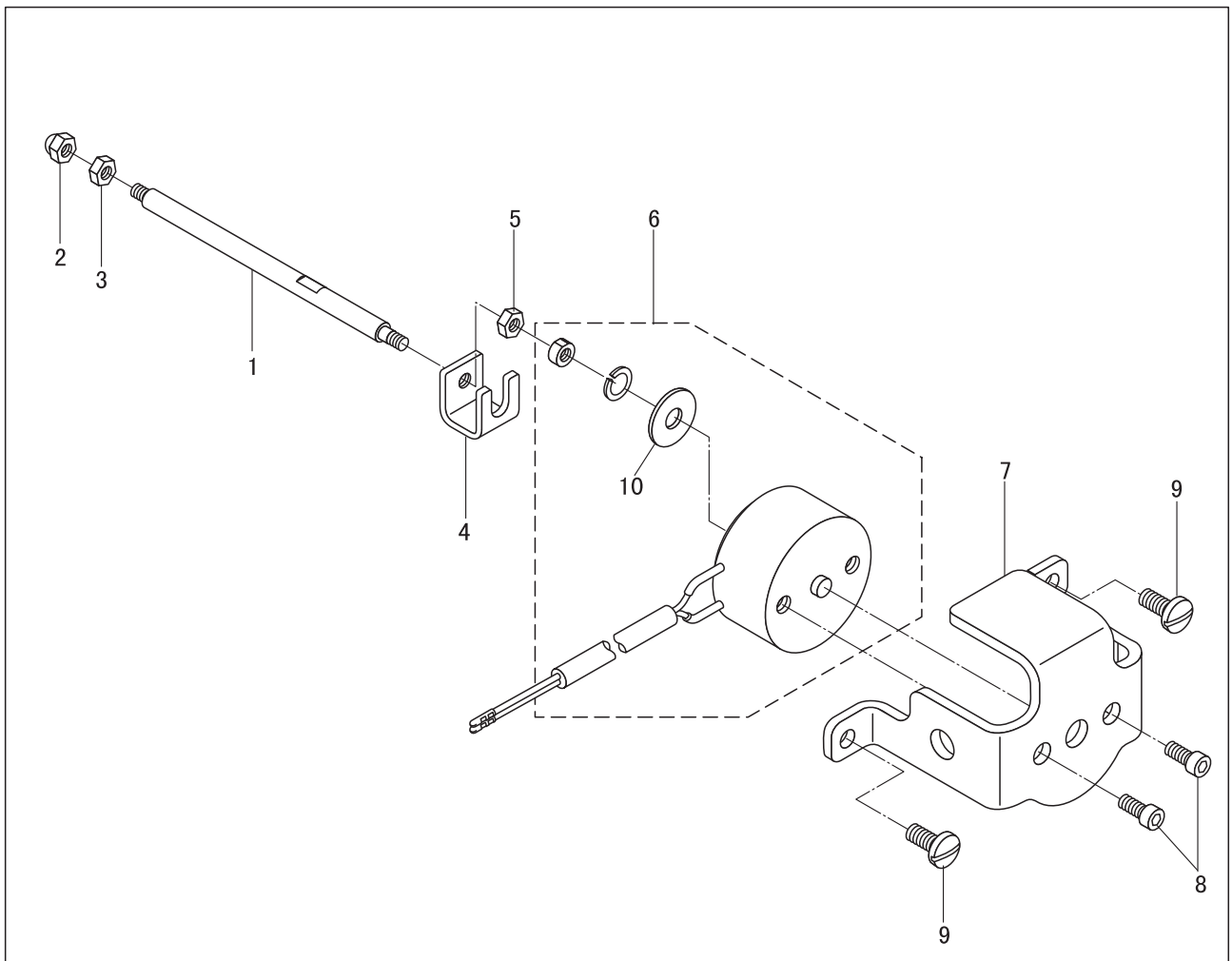

No.	Part Number	Name	Qt.	Remark
1	119WF9-004	Tension release shaft	1	
2		Nut	1	GB923 M4
3	11KT3-021	Nut	1	
4	119WF9-003	Solenoid joint	1	
5	11KT3-021	Nut	1	
6	119WF9-001	Tension release solenoid	1	
7	119WF9-002	Solenoid installing base	1	
8		Screw	2	GB/T70.1 M4×5
9	7WF5-017	Screw	2	
10	228WF2-004	Washer	1	

12.Auto-lifer mechanism

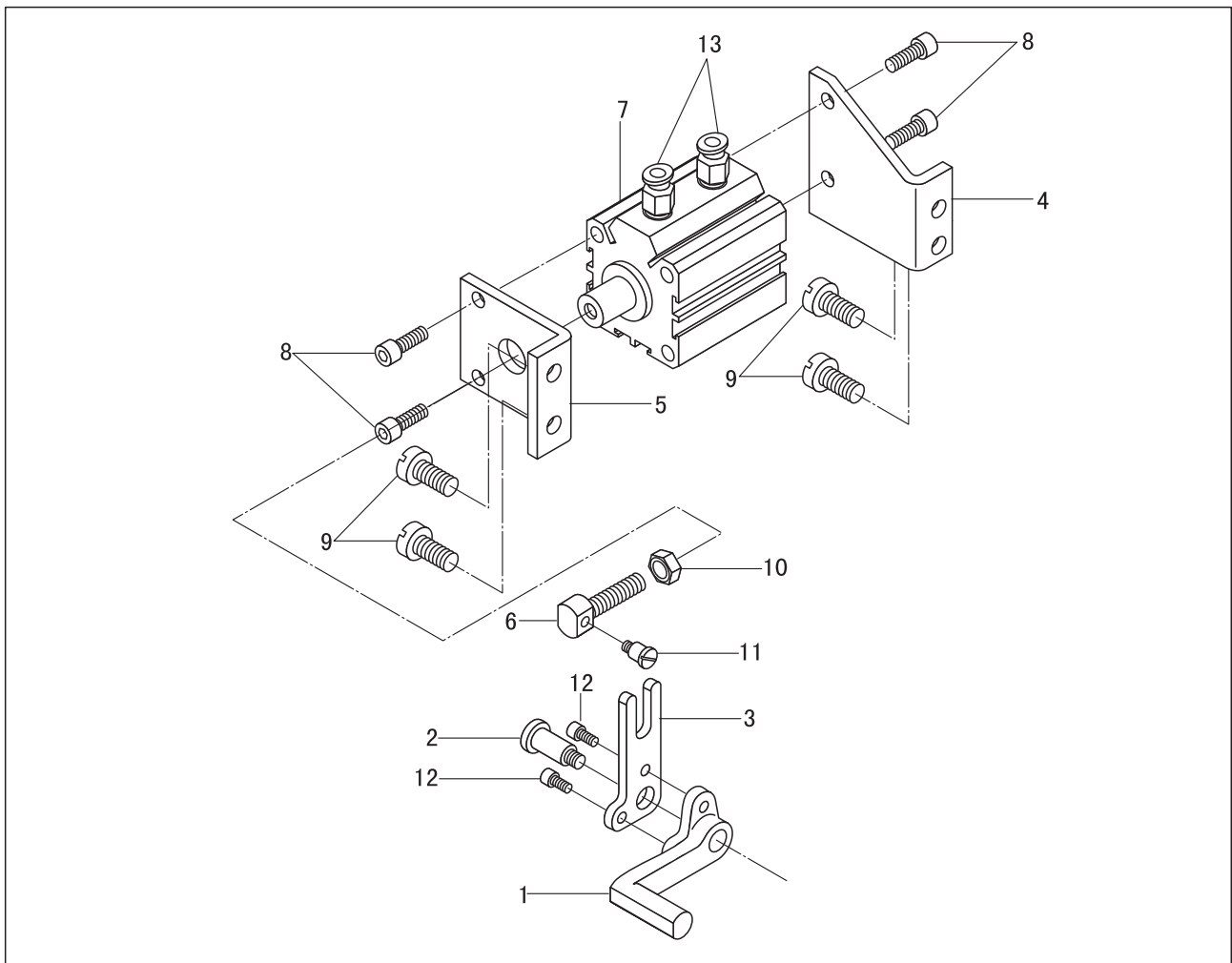

No.	Part Number	Name	Qt.	Remark
1	228WF5-001	Crank	1	
2	228WF5-002	Screw	1	
3	228WF5-003	Driven lever	1	
4	228WF5-004	Cylinder support(1)	1	
5	228WF5-005	Cylinder support(2)	1	
6	228WF5-006	Connector	1	
7	228WF5-008	Cylinder	1	
8	7KT1-003	Screw	4	M6 × 20
9	13WF2-045	Screw	4	SM15/64" × 28
10		Nut	1	GB/T6170 M8
11	228WF5-007	Screw	1	
12	13WF6-010	Screw	2	M5 × 10
13	93WF22-006	Joint	2	APC6-01

13.Lubrication components

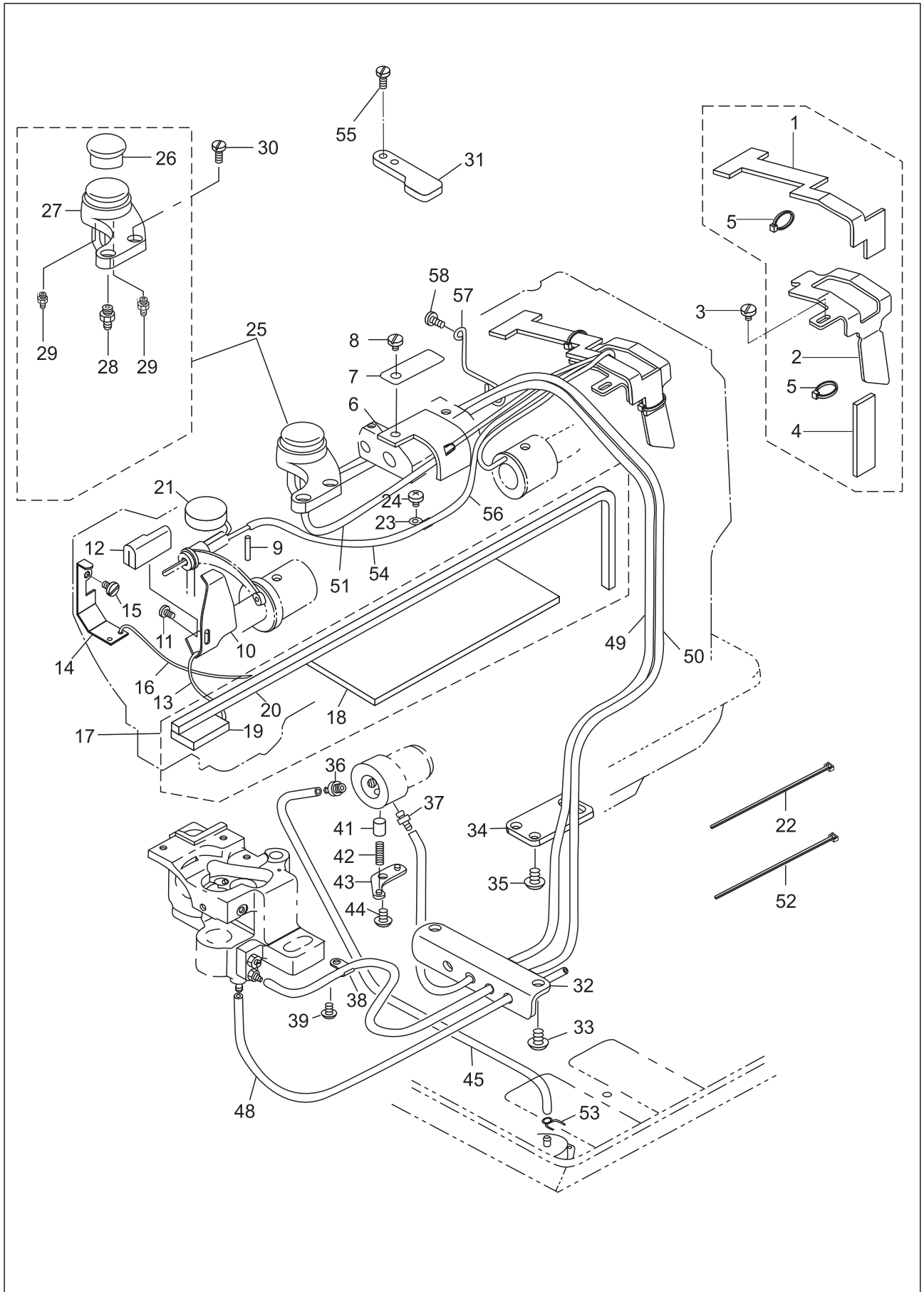

13.Lubrication components

No.	Part Number	Name	Qt.	Remark
1	92WF5-001	Oil felt	1	
2	92WF5-002	Bracket	1	
3	1WF1-011	Screw	1	SM11/64" × 40
4	92WF5-003	Oil felt	1	
5	2KT7-001A	Band	2	
6	119WF5-003	Oil felt	1	
7	119WF5-001	Plate	1	
8	119WF5-002	Screw	1	
9	92WF5-010	Oil felt	1	
10	92WF5-011	Oil shield	1	
11	16WF1-059	Screw	1	SM9/64" × 40
12	92WF5-012	Oil felt	1	
13		Oil wick	1	Φ2 × 250
14	92WF5-013	Oil shield	1	
15	36WF1-031D	Screw	1	SM11/64" × 40
16		Oil wick	1	Φ2 × 250
17	92WF5-014	Oil felt assy.	1	
18	92WF5-014A	Felt	1	
19	92WF5-014B	Felt	1	
20	92WF5-014C	Oil wick	1	
21	92WF5-009	Felt	1	
22	2KT7-001A	Band	1	
23	1WF6-036	Clip	1	
24	17WF1-020	Screw	1	SM11/64" × 40
25	199WF6-001	Oil box assy.	1	
26	199WF6-001A	Oil window	1	
27	199WF6-001B	Oil box	1	
28	199WF6-002	Connector	1	
29	199WF1-048	Connector	2	
30	1WF5-042	Screw	2	SM11/64" × 40
31	92WF5-004	Plate	1	
32	199WF6-003	Oil tube support	1	
33	27WF5-005	Screw	2	SM15/64" × 28
34	199WF6-004	Supporter	1	
35	27WF5-005	Screw	2	SM15/64" × 28
36	199WF6-005	Connector	1	
37	199WF1-048	Connector	1	
38	1WF6-036	Clip	1	

13.Lubrication components

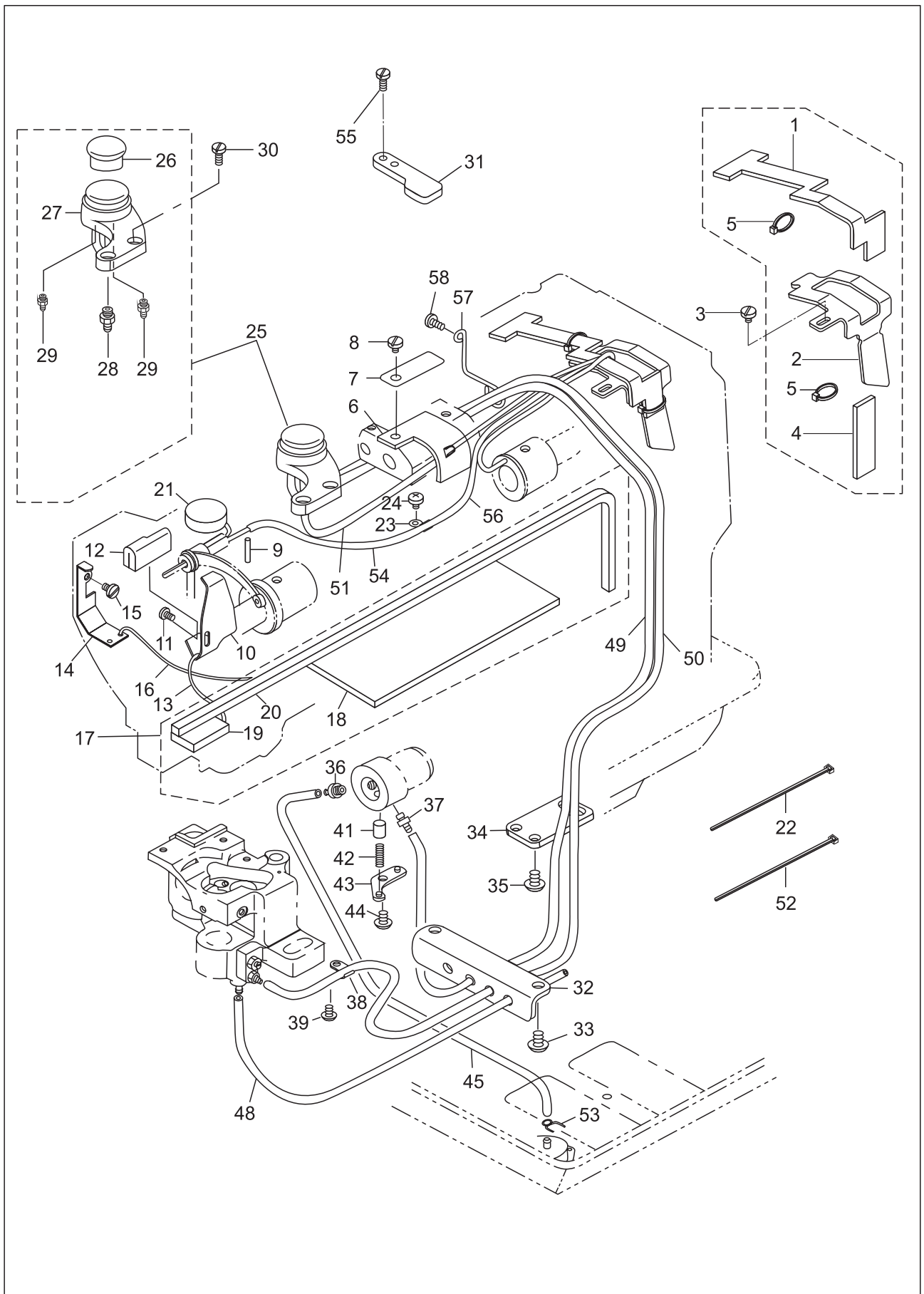

13.Lubrication components

No.	Part Number	Name	Qt.	Remark
39	17WF1-020	Screw	1	SM11/64" × 40
41	199WF6-007	Plug	1	
42	199WF6-008	Spring	1	
43	199WF6-009	Plate	1	
44	17WF1-020	Screw	1	SM11/64" × 40
45	199WF6-010	Oil tube	1	Φ5 × 1 L=370
48	199WF6-013	Oil tube	1	Φ5 × 1 L=300
49	199WF6-014	Oil tube	1	Φ5 × 1 L=690
50	199WF6-015	Oil tube	1	Φ5 × 1 L=720
51	199WF6-016	Oil tube	1	Φ5 × 1 L=200
52	2KT5-001A	Band	11	
53	199WF6-017	Clip	1	
54	199WF6-018	Oil tube	1	Φ5 × 1 L=225
55	W01111	Screw	2	
56	199WF6-019	Oil wick	1	Φ5 × 480
57	199WF6-020	Setting hook	1	
58	36WF4-017	Screw	1	

14. Accessories

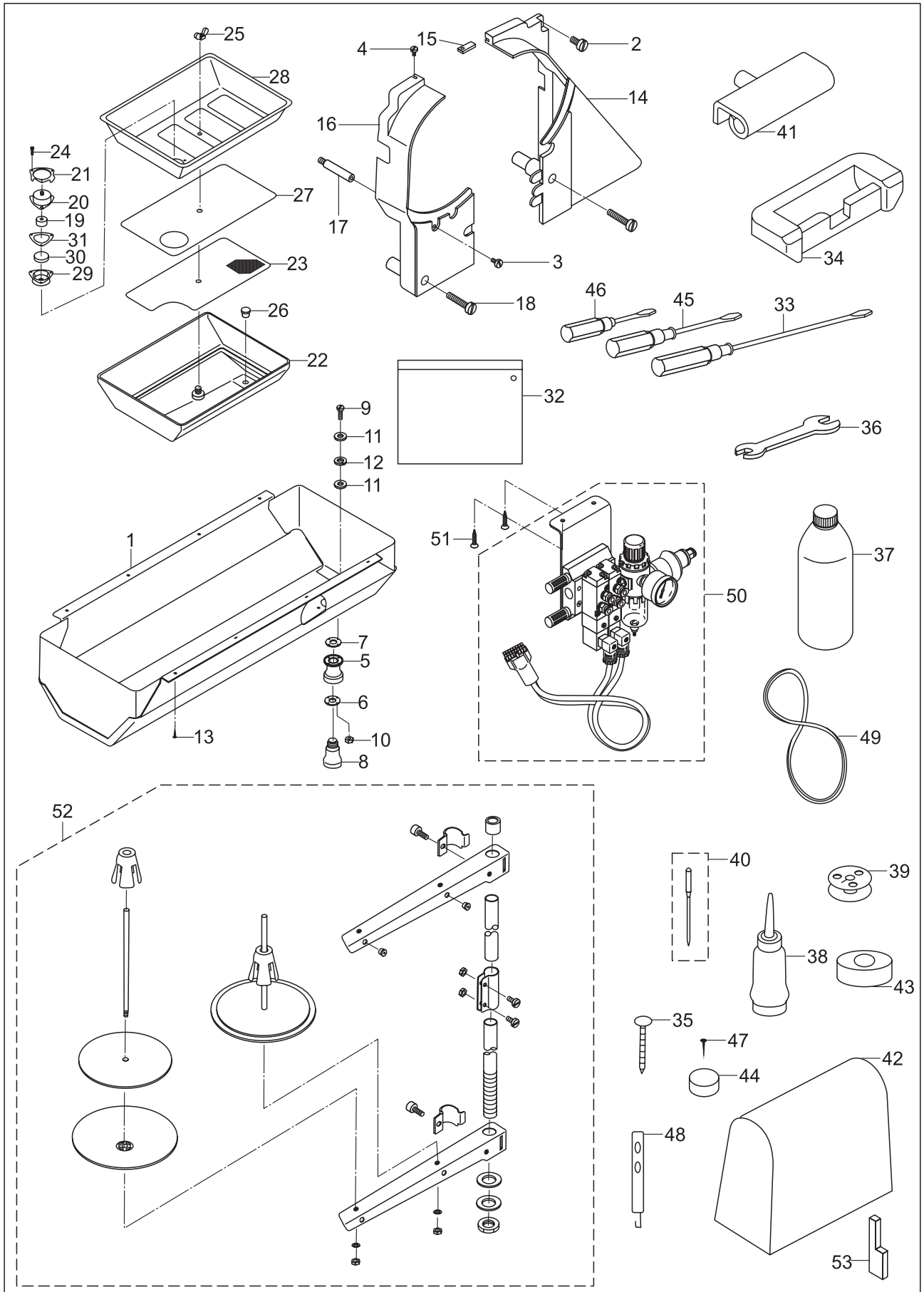

14. Accessories

No.	Part Number	Name	Qt.	Remark
1	199WF7-001	Big oil pan	1	
2	21WF3-012	Screw	1	SM15/64" × 28
3	42WF2-008	Screw	1	SM11/64" × 40
4	2KT6-012	Screw	1	SM11/64" × 40
5	92WF6-018	Oil bolt	1	
6	92WF6-020	Washer	1	
7	92WF6-019	Seal	1	
8	92WF6-027	Waste oil pot	1	
9		Screw	4	GB/T818 M3 × 14
10		Nut	4	GB/T6170 M3
11	92WF6-023	Spacer	8	
12		Washer	4	GB/T95 M3
13		Wooden screw	8	GB99 2.5 × 16
14	92WF6-013B	Belt cover (R)	1	
15	92WF6-013C	Connector	1	
16	92WF6-013A	Belt cover (L)	1	
17	92WF6-016	Supporting pole	1	
18	1WF2-060	Screw	2	SM15/64" × 28
19	199WF7-002	Filter element	1	
20	199WF7-003	Cap	1	
21	199WF7-004	Fix piece	1	
22	199WF7-005	Small oil pan	1	
23	199WF7-006	Supporter	1	
24		Screw	3	GB/T65 M2 × 10
25		Screw	1	GB62 M5
26	199WF7-007	Plug	1	
27	199WF7-008	Filter	1	
28	199WF7-009	Tray	1	
29	199WF7-010	Case	1	
30	199WF7-011	Magnet	1	
31	199WF7-012	Seal	1	
32	33TF-010	Accessories bag	1	
33	33TF-012	Screwdriver (big)	1	
34	22T9-007F2	Hinge cushion	1	
35		Nail	8	3/4
36	92WF6-028	Wrench	1	
37	1F-009	Big oil pot	1	
38	33TF-011	Small oil pot	1	

14. Accessories

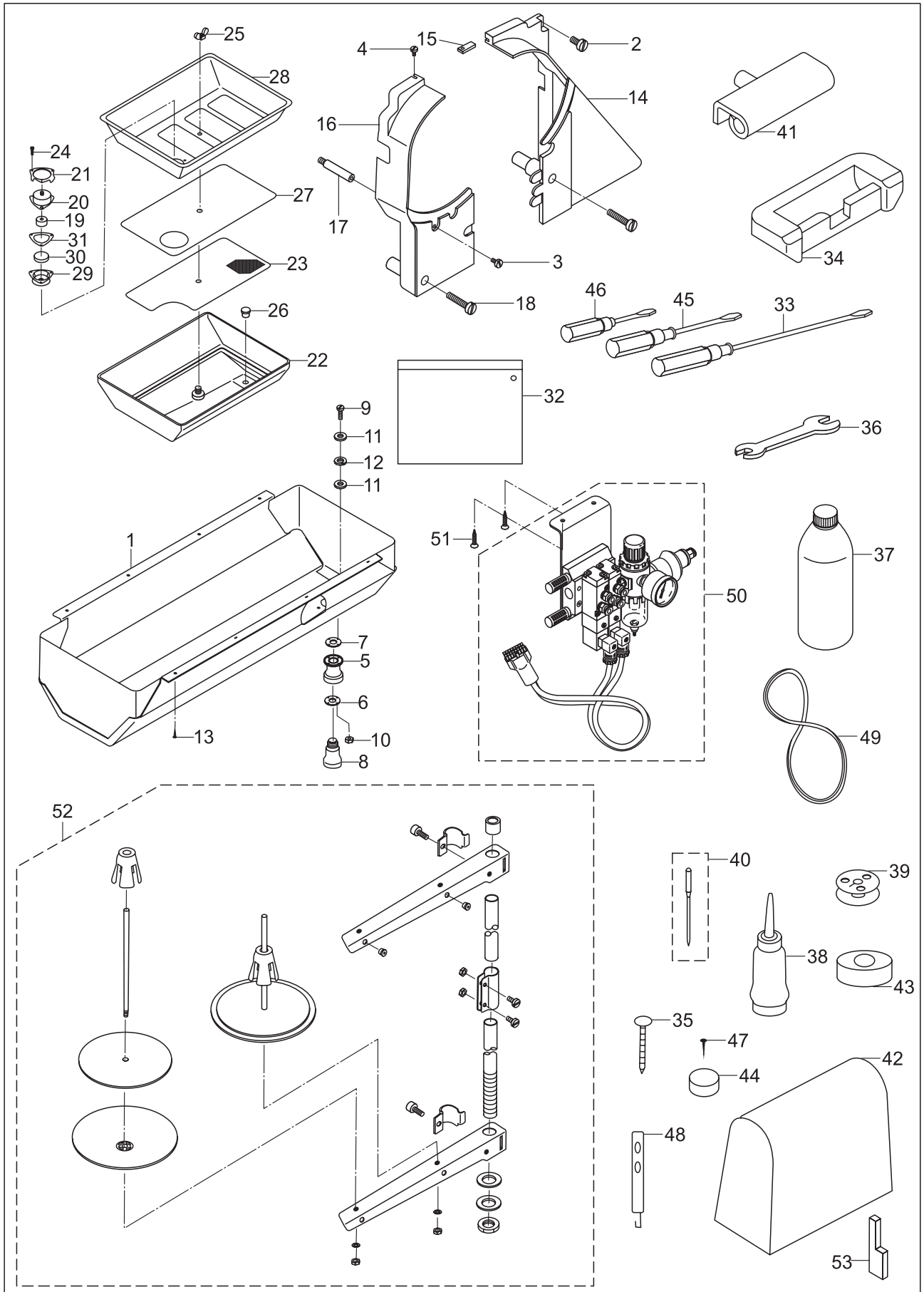

14. Accessories

No.	Part Number	Name	Qt.	Remark
39	228WF1-011	Bobbin	3	
40		Needle	3	DP × 17 23#
41	22T9-007F1	Bed hinge	2	
42	13F-002	Machine head cover	1	
43	92WF6-025	Cushion	1	
44	92WF6-026	Oil felt	4	
45	33TF-013	Screwdriver (M)	1	
46	33TF-014	Screwdriver(S)	1	
47		Nail	1	SG162 L=19
48	92WF2-037	Thread finger	1	
49		V-belt	1	M42
50	93WF22-	Integrator assy.	1	
51		Screw	1	GB100 3 × 16
52	33TF-019	Thread stand assy.	1	
53	228WF6-001	Fixed knife gauge	1	